

1                   **Title 10 DEPARTMENT OF HEALTH AND MENTAL HYGIENE**

2                   **Subtitle 17 [SWIMMING POOLS AND SPAS] *AQUATIC FACILITIES AND VENUES***

3                   **Chapter 01 [Public Swimming Pools and Spas] *Aquatic Facilities and Venues***

4                   **Authority: Health-General Article, §§2-102, 2-104, 18-102, and 20-303, Annotated Code of**  
5                   **Maryland, and U.S.C. §8003**

6                   **.01 Purpose and Scope.**

7                   A. The purpose of this chapter is to enact regulations that protect and promote the public health  
8                   and safety of individuals at [public spas and pools] *aquatic facilities and venues* in Maryland.  
9                   [Public pools] *Aquatic facilities and venues* include limited public-use pools, recreational pools,  
10                  [and semipublic pools. Public spas include semipublic spas] *semipublic pools, public spas,*  
11                  *semipublic spas, and public spray grounds.*

12                  B. This chapter adopts construction standards, updates disinfection standards, recognizes certain  
13                  new technologies and design concepts, and establishes minimum [criteria for public pools and  
14                  spas] *standards for aquatic facilities and venues.*

15                  **.02 Exclusions.**

16                  This chapter does not apply to a:

17                  A. Private pool, except for a private pool defined as a limited public-use pool in Regulation .04B  
18                  of this chapter;

19                  B. Private spa;

20                  C. Pool or spa that is completely emptied of water, disinfected, and refilled with water between  
21                  each use and that is intended for use or used by a single individual during each use; [or]

22                  D. Pool [or a], spa, *or spray ground* at a bed and breakfast, if the bed and breakfast facility has  
23                  eight or fewer guest rooms[.]; *or*

24                  E. *Private spray ground.*

25                  **.03 [Previously Constructed Pools and Spas.]**

26                  A. Except as provided in §C of this regulation, the owner of a pool or spa that was constructed  
27                  before February 10, 1997 is exempt from bringing the pool or spa into compliance with:

28                  (1) Regulations .13C, .14A(3), .17C, .18A(3), .22, .24, and .35 of this chapter; and

## Draft Regulations for COMAR 10.17.01 – Aquatic Facilities and Venues

1 (2) Notwithstanding any exemption set forth at §A(1) of this regulation, the diving area  
2 dimensions of Regulation .27B of this chapter if the diving area is in compliance with American  
3 National Standard for Public Swimming Pools.

4 B. Except for Regulation .28 of this chapter, the owner of a pool or spa that was constructed  
5 before February 10, 1997:

6 (1) Shall maintain the pool or spa, including appurtenant structures and equipment as originally  
7 constructed; and

8 (2) May complete a repair according to Regulation .06P that restores the pool or spa to its  
9 original condition before damage or deterioration without the component complying with the  
10 requirements of this chapter.

11 C. For a pool or spa that was constructed before February 10, 1997, the exemptions in §A of this  
12 regulation do not apply if:

13 (1) The pool or spa has a condition that jeopardizes the health or safety of the public, in which  
14 case the owner shall ensure that the condition is corrected to meet the requirements of this  
15 chapter;

16 (2) An owner intends to alter the pool or spa, including appurtenant structures and equipment in  
17 which case the owner shall ensure that the alteration complies with the requirements of this  
18 chapter; or

19 (3) A suction outlet is not in compliance with Regulation .28 of this chapter, in which case the  
20 owner shall ensure that the suction outlet is altered to meet the requirements of Regulation .28 of  
21 this chapter for suction entrapment prevention.]

### 22 ***Documents Incorporated by Reference.***

23 *The following documents are incorporated by reference in this chapter:*

24 *A. American National Standard for Public Swimming Pools (ANSI/APSP/ICC-1 2014) except*  
25 *Articles 6.8, 6.9.1, 6.9.3, 7.1.6, 7.1.7, 7.1.7.1, 8.1.1, 12.3, 12.3.1, 12.3.2, 13.2.1.2, 13.2.3,*  
26 *15.3,.17.4, 17.5.1, 18.1, 18.1.2, 18.1.2.1, 18.1.2.2, 18.1.2.3, 18.6, and 22.2.1, and except that in*  
27 *Appendix E, the term "shall" is substituted for "should" whenever it appears;*

28 *B. American National Standard for Public Spas, (ANSI/NSPI-2 1999), except Articles 7.6 and*  
29 *7.6.1;*

30 *C. Circulation System Components and Related Materials for Pools, Spas/Hot Tubs (NSF/ANSI-*  
31 *50 2013);*

32 *D. American National Standard for Residential Inground Swimming Pools (ANSI/APSP/ICC-5*  
33 *2011);*

## Draft Regulations for COMAR 10.17.01 – Aquatic Facilities and Venues

- 1 *E. American National Standard for Aboveground/Onground Residential Swimming Pools*
- 2 *(ANSI/APSP/ICC-4 2012);*
- 3 *F. American National Standard for Suction Fittings for Use in Swimming Pools, Wading Pools,*
- 4 *Spas, and Hot Tubs (ANSI/APSP-16 2011); and*
- 5 *G. 15 U.S.C. §8003, as amended.*

**Summary of changes:** Updates references to regulations incorporated by reference.

**MAHC:** Specific sections of the 2016 2<sup>nd</sup> edition MAHC will be incorporated by reference, but not as amended. These sections are to be determined.

**Relevant comments:**

- 2015-016
- 2017-081
- 2017-082
- 2017-137
- 2017-163
- 2017-164

### 6 **.04 [Documents Incorporated by Reference.**

7 The following documents are incorporated by reference in this chapter:

- 8 A. American National Standard for Public Swimming Pools (ANSI/NSPI-1 2003) except
- 9 Articles 6.5, 6.5.1, 6.6, 6.6.1, 6.6.2, 6.6.3, 6.8, 6.9.1, 6.9.3, 7.1.6, 7.1.7, 7.1.7.1, 8.1.1, 8.4.2.1,
- 10 8.4.2.3, 12.3.1, 12.3.2, 13.2.1, 13.2.3, 15.3, 17.4.1, 17.5.1, 18.6, and 22.2.1, and except that in
- 11 Appendix E, the term "shall" is substituted for "should" whenever it appears;
- 12 B. American National Standard for Public Spas, (ANSI/NSPI-2 1999), except Articles 7.6 and
- 13 7.6.1;
- 14 C. Circulation System Components and Related Materials for Pools, Spas/Hot Tubs (ANSI/NSF
- 15 Standard-50 1992);
- 16 D. American National Standard for Residential Inground Swimming Pools (ANSI/NSPI-5 1995)
- 17 including Appendix E, Model Barrier Code for Residential Swimming Pools, Spas, and Hot
- 18 Tubs;
- 19 E. American National Standard for Aboveground/Onground Residential Swimming Pools
- 20 (ANSI/NSPI-4 1992); and
- 21 F. 15 U.S.C. §8003, as amended.]

## Draft Regulations for COMAR 10.17.01 – Aquatic Facilities and Venues

### 1 **Definitions.**

2 *A. In this chapter, the following terms have the meanings indicated.*

3 *B. Terms Defined.*

4 *(1) “Agitated water” means an aquatic venue with mechanical means to discharge, spray, or*  
5 *move the water's surface above and/or below the static water line of the aquatic venue so people*  
6 *are standing or playing vertically.*

7 *(1-1) “AF” means alkalinity factor.*

8 *(2) Alteration.*

9 *(a) “Alteration” means to:*

10 *(i) Change or modify an equipment room, a bathhouse, a component, or the configuration of an*  
11 *aquatic venue;*

12 *(ii) Move a component from one location or position to another; or*

13 *(iii) Install a new component.*

14 *(b) “Alteration” does not include a repair or replacement.*

15 *(3) “Approved” means found by the Secretary to be in satisfactory compliance with applicable*  
16 *statutes and regulations promulgated or enforced by the Secretary.*

17 *(4) “APSP” means the Association of Pool and Spa Professionals.*

18 *(5) “Aquatic facility” means a physical place that contains one or more aquatic venues and*  
19 *support infrastructure.*

20 *(6) Aquatic venue.*

21 *(a) “Aquatic venue” means an artificially constructed structure or modified natural structure*  
22 *where the general public is exposed to water intended for recreational or therapeutic purpose.*

23 *(b) “Aquatic venue” includes a public pool, spa, and spray ground.*

24 *(c) “Aquatic venue” does not include a private pool, spa, or spray ground.*

25 *(7) “Barrier” means a fence, wall, or a combination of a fence and wall that completely*  
26 *surrounds and obstructs access to the aquatic venue.*

27 *(7-1) “CF” means calcium hardness factor.*

Draft Regulations for COMAR 10.17.01 – Aquatic Facilities and Venues

- 1 (8) “Cfm” means cubic feet per minute.
- 2 (9) “Component” means:
- 3 (a) A piece of aquatic venue equipment;
- 4 (b) A deck;
- 5 (c) A barrier;
- 6 (d) One or more skimmers;
- 7 (e) One or more filters, including piping and valves;
- 8 (f) A ventilation system;
- 9 (g) Lighting provided for water, deck, and walkways; or
- 10 (h) Pipe material for aquatic venue water.
- 11 (9-1) “CPR” means cardiopulmonary resuscitation.
- 12 (10) “Critical violation” means failure to comply with:
- 13 (a) Regulation .06;
- 14 (b) Regulation .06-1;
- 15 (c) Regulation .08;
- 16 (d) Regulation .21;
- 17 (e) Regulation .25;
- 18 (f) Regulation .28;
- 19 (g) Regulation .29;
- 20 (h) Regulation .40;
- 21 (i) Regulation .43;
- 22 (j) Regulation .44;
- 23 (k) Regulation .45;

## Draft Regulations for COMAR 10.17.01 – Aquatic Facilities and Venues

- 1 (l) Regulation .46; and
- 2 (m) Regulation .48.
- 3 (11) “Deck” means surface areas serving the aquatic venue, including the dry deck, perimeter  
4 deck, and pool deck.
- 5 (12) “Department” means the Department of Health and Mental Hygiene.
- 6 (12-1) “DPD” means diethyl-p-phenylene diamine.
- 7 (13) Dry deck.
- 8 (a) “Dry deck” means all pedestrian surface areas within the aquatic venue barrier not subject  
9 to frequent splashing or constant wet foot traffic.
- 10 (b) “Dry deck” does not include perimeter deck, pool deck or landscape areas.
- 11 (13-1) “EDTA” means ethylenediamine-tetraacetate.
- 12 (14) “Flat water” means an aquatic venue in which the water line is static except for movement  
13 made by users usually as a horizontal use as in swimming or from diving spargers.
- 14 (15) “Full compliance inspection” means an inspection that verifies compliance with this  
15 chapter.
- 16 (16) “Gpm” means gallons per minute.
- 17 (17) “Handhold” means a coping, horizontal bar, or cantilevered decking.
- 18 (18) “Latch” means a device attached to a gate for the purpose of securing the gate closed.
- 19 (19) Latch release.
- 20 (a) “Latch release” means a mechanism to disengage the latch to allow the gate to open.
- 21 (b) “Latch release” includes but is not limited to an electronic lock, a key fob system, or a swipe  
22 card entry system.
- 23 (20) “Lazy river” means an aquatic venue where water is moved by pumps or other means of  
24 propulsion that transports bathers over a defined path.
- 25 (21) “Lifeguard” means an individual who is 15 years old or older and who has a valid lifeguard  
26 certificate from:
- 27 (a) The American Red Cross;

## Draft Regulations for COMAR 10.17.01 – Aquatic Facilities and Venues

- 1 (b) *The Boy Scouts of America, not including a lifeguard merit badge;*  
2 (c) *The Young Men's Christian Association;*  
3 (d) *Ellis and Associates' National Pool and Waterpark Lifeguard Training;*  
4 (e) *Starfish Aquatics Institute; or*  
5 (f) *An organization with a lifesaving training program equivalent to that of the American Red*  
6 *Cross as determined by the Department.*
- 7 (22) *Limited public-use pool.*
- 8 (a) *"Limited public-use pool" means a private pool which is made available for use by:*
- 9 (i) *Children in family day care under the care of a family day care provider at a family day care*  
10 *home as defined in COMAR 13A.15.01; or*
- 11 (ii) *An organized group, agency, or other person for swimming lessons or water safety training.*
- 12 (b) *"Limited public-use pool" does not include a pool that is emptied of water, disinfected, and*  
13 *refilled with water between each use.*
- 14 (23) *"Make-up water" means the potable water used to maintain the water level in a pool, spa,*  
15 *or within the surge tank of a spray ground.*
- 16 (24) *"NSF" means the National Sanitation Foundation International.*
- 17 (25) *"Operator" means a person who supervises, controls, conducts, or manages the operation*  
18 *of an aquatic facility or venue.*
- 19 (26) *"Owner" means a person who has a legal interest in an aquatic facility or venue or in the*  
20 *property on which an aquatic facility or venue is or is to be constructed or altered.*
- 21 (27) *"Oxidation reduction potential (ORP)" means a measure of the tendency for a solution to*  
22 *either gain or lose electrons.*
- 23 (28) *"Perimeter deck" means the hardscape surface area immediately adjacent to and within*  
24 *four feet of the edge of the public pool, spa or spray ground.*
- 25 (29) *"Person" means an individual, receiver, trustee, guardian, personal representative,*  
26 *fiduciary, or representative of any kind and any partnership, firm, association, corporation, or*  
27 *other entity.*
- 28 (30) *"PHMB" means poly (iminoimidocarbonyliminoimidocarbonyliminohexamethylene*  
29 *hydrochloride) or polyhexamethylene biguanidine hydrochloride.*

## Draft Regulations for COMAR 10.17.01 – Aquatic Facilities and Venues

1 (31) *“Plummet” means the center of the end of the diving board over the water, in the position*  
2 *where it will be installed.*

3 (32) *“Pool” means an artificial enclosure of water that is used for the immersion of the human*  
4 *body for recreation, therapy, or exercise, including a structure that is installed in the ground,*  
5 *above ground, outside, or in a building or portable structure.*

6 (33) *“Pool deck” means the surface areas serving the aquatic venue, beyond perimeter deck,*  
7 *which is expected to be regularly trafficked and made wet by bathers.*

8 (34) *“Ppm” means parts per million.*

9 (35) *“Primary disinfectant” means chlorine or bromine.*

10 (36) *Private pool, private spa, and private spray ground.*

11 (a) *“Private pool,” “private spa,” and “private spray ground” mean a pool, spa, or spray ground*  
12 *that is:*

13 (i) *Not open to the public;*

14 (ii) *On a property on which not more than eight private residences are located; and*

15 (iii) *Used exclusively by the residents of the property and nonpaying individuals invited to use*  
16 *the pool, spa, or spray ground by a resident.*

17 (b) *“Private pool,” “private spa,” or “private spray ground” include a pool, spa, or spray*  
18 *ground at a private residence used for short-term rentals including weekly, monthly, or seasonal*  
19 *rentals.*

20 (37) *“PSI” means pounds per square inch.*

21 (38) *Public pool, public spa, and public spray ground.*

22 (a) *“Public pool,” “public spa,” and “public spray ground” mean a pool, spa, or spray ground*  
23 *that is not a private pool, spa, or spray ground.*

24 (b) *“Public pool” includes a:*

25 (i) *Limited public-use pool;*

26 (ii) *Recreational pool; and*

27 (iii) *Semipublic pool.*

28 (c) *“Public spa” includes a semipublic spa.*



Draft Regulations for COMAR 10.17.01 – Aquatic Facilities and Venues

1 (39) “Recreational pool” means a pool that:

2 (a) Is not a limited public-use pool, private pool, semipublic pool, or spray ground;

3 (b) Is provided as the owner's primary business or the facility's primary purpose, for example, a  
4 swim club or similar facility;

5 (c) Is open for general admission to the public;

6 (d) Is available to an individual paying a fee for use of the pool;

7 (e) Is equipped with a sliding board, diving platform, water slide, water flume, or water  
8 recreational play equipment that is built into or attached to the pool structure;

9 (f) Is provided by, or used by a:

10 (i) Youth camp;

11 (ii) College, university, or school;

12 (iii) Municipality;

13 (iv) Water park, amusement park, or water recreational attraction; or

14 (v) An apartment complex, housing subdivision, or mobile home park with more than ten units,  
15 except as provided in §B(45) of this regulation; or

16 (g) Is used more than 4 times a week for swimming lessons, water safety instruction, or  
17 swimming competition.

18 (40) Repair.

19 (a) “Repair” means substituting a component having the same make and model as the previously  
20 approved component for the previously approved component.

21 (b) “Repair” does not include:

22 (i) Replacements;

23 (ii) Alterations;

24 (iii) Installation of additional equipment; or

25 (iv) Substitutions involving a component which does not meet the requirements of this chapter.

26 (41) Replacement.

## Draft Regulations for COMAR 10.17.01 – Aquatic Facilities and Venues

- 1 (a) “Replacement” means substituting a component, which has a different make or model but  
2 has the same operating characteristics and certifications as the previously approved component,  
3 for the previously approved component.
- 4 (b) “Replacement” does not include:
- 5 (i) Repairs;
- 6 (ii) Alterations;
- 7 (iii) Installation of additional equipment; or
- 8 (iv) Substitutions involving a component which does not meet the requirements of this chapter.
- 9 (c) “Replacement” includes the installation of any component which is being installed at an  
10 aquatic facility that received approval after construction from the Secretary prior to May 30,  
11 2016, to bring an aquatic facility into compliance with new provisions of this chapter.
- 12 (42) “Routine inspection” means an inspection that includes but is not limited to verifying  
13 compliance with:
- 14 (a) Regulation .40;
- 15 (b) Regulation .44;
- 16 (c) Regulation .45;
- 17 (d) Regulation .46;
- 18 (e) Regulation .48; and
- 19 (f) Regulation .48-1.
- 20 (43) “Safety vacuum release system” means a vacuum release system that:
- 21 (a) Is capable of providing vacuum release at a suction outlet caused by a high vacuum  
22 occurrence due to a suction outlet flow blockage; and
- 23 (b) Complies with 15 U.S.C. §8003.
- 24 (44) “Secretary” means the Secretary of Health and Mental Hygiene or the Secretary's designee,  
25 including a local health officer.
- 26 (45) “Semipublic pool” and “semipublic spa” means a pool or spa at a facility that:
- 27 (a) Has pool use or spa use restricted to an individual:

## Draft Regulations for COMAR 10.17.01 – Aquatic Facilities and Venues

- 1 *(i) Staying at the facility, where the facility is a temporary dwelling, including a hotel, motel,*  
2 *campground, bed and breakfast having nine or more guest rooms, or similar temporary*  
3 *dwelling;*
- 4 *(ii) Holding membership at the facility, where the facility is an adult health club, retirement*  
5 *community, marina, condominium, or similar facility;*
- 6 *(iii) Residing at an apartment complex, housing subdivision, or mobile home park with ten units*  
7 *or less;*
- 8 *(iv) Receiving treatment at a physical therapy center pool or spa, where the pool or spa is used*  
9 *for providing therapy; or*
- 10 *(v) Who is the owner or an owner of the pool or spa; and*
- 11 *(b) Has a pool or spa that is not:*
- 12 *(i) Open for admission to the general public, except as provided in §B(45) of this regulation;*
- 13 *(ii) Available to an individual upon the payment of a fee for the use of the pool and spa;*
- 14 *(iii) A limited public-use pool, a private pool, a private spa, a private spray ground, a*  
15 *recreational pool, or a spray ground;*
- 16 *(iv) Equipped with a swimming pool sliding board, diving platform, water slide, water flume, or*  
17 *water recreational play equipment that is built into or attached to the pool structure; and*
- 18 *(v) At a bed and breakfast that has eight or fewer guest rooms.*
- 19 *(46) "Shallow" means 5 feet or less in depth.*
- 20 *(47) Spa.*
- 21 *(a) "Spa" means a pool, hot tub, or whirlpool that is:*
- 22 *(i) Primarily designed for relaxation or therapeutic use and not for swimming;*
- 23 *(ii) Not more than 4 feet in depth;*
- 24 *(iii) Equipped with built-in seats or benches; and*
- 25 *(iv) Usually equipped with hydrotherapy jets, heated water, an air injection system, or some*  
26 *combination of these features.*
- 27 *(b) "Spa" does not include a pool, hot tub, or whirlpool classified as a swim spa.*

## Draft Regulations for COMAR 10.17.01 – Aquatic Facilities and Venues

- 1 (48) *“Splash zone” means the maximum distance the water from a spray ground can project*  
2 *horizontally at designed flow rates.*
- 3 (49) *Spray ground.*
- 4 (a) *“Spray ground” means an area for water play into which treated and filtered water is*  
5 *sprayed but not allowed to accumulate on the play surface.*
- 6 (b) *“Spray ground” includes splash pads and interactive fountains.*
- 7 (c) *“Spray ground” does not include decorative fountains where interaction with the water is*  
8 *prohibited.*
- 9 (50) *“Stadium seating” means an area of high-occupancy seating provided above the pool level*  
10 *for observation.*
- 11 (51) *“Supplemental disinfectant” means, other than chlorine or bromine, any disinfectant,*  
12 *sanitizer, or antimicrobial pesticide approved by the Environmental Protection Agency.*
- 13 (52) *“Swimming pool slide” means a water-contact device less than 10 feet in height that an*  
14 *individual may use to enter a pool by sliding down an inclined plane.*
- 15 (53) *“Swim spa” means a spa designed to create a current of water against which an individual*  
16 *may swim for exercise or therapy.*
- 17 (53-1) *“TDSF” means total dissolved solids factor.*
- 18 (53-2) *“TF” means temperature factor.*
- 19 (54) *Theoretical peak occupancy.*
- 20 (a) *“Theoretical peak occupancy” means the anticipated peak number of bathers in an aquatic*  
21 *venue and the anticipated peak number of occupants on the decks of an aquatic facility.*
- 22 (b) *“Theoretical peak occupancy” is calculated by dividing the surface area in square feet of the*  
23 *aquatic venue by the density factor (D) in Regulation .19B of this chapter, that fits the specific*  
24 *aquatic venue being considered.*
- 25 (55) *“Therapy pool” means a pool that is exclusively used in the physical treatment of a disease,*  
26 *injury, or disorder.*
- 27 (56) *“Total dynamic head” means the hydraulic calculation of the resistance to flow in a*  
28 *circulation system based on the Hazen-Williams formula in Regulation .25C of this chapter.*
- 29 (57) *“Tube ride” means a pool designed to move an individual on a tube, raft, or other floating*  
30 *support along a channel filled with water.*

## Draft Regulations for COMAR 10.17.01 – Aquatic Facilities and Venues

- 1 (58) "Turnover rate" means the time required to circulate a quantity of water equal to the pool  
2 or spa volume or for a spray ground, the surge tank volume.
- 3 (59) "Unblockable drain" means a suction outlet such that:
- 4 (a) Its perforated area cannot be shadowed by the area of the 18 inch by 23 inch body blocking  
5 element of the American National Standard for Suction Fittings for Use in Swimming Pools,  
6 Wading Pools, Spas, and Hot Tubs (ANSI/APSP-16 2011); and
- 7 (b) The rated flow through the remaining open area cannot create a suction force in excess of  
8 the removal force values in Table 1 of American National Standard for Suction Fittings for Use  
9 in Swimming Pools, Wading Pools, Spas, and Hot Tubs (ANSI/APSP-16 2011).
- 10 (60) User load.
- 11 (a) "User load" means the maximum number of individuals, as determined by the Secretary, for  
12 sanitary purposes, allowed:
- 13 (i) In a pool or spa based on the water surface area and water depths; or
- 14 (ii) To use a spray ground based on the splash zone area.
- 15 (61) "Wading pool" means a pool with a water depth of 24 inches or less that is intended for use  
16 by children.
- 17 (62) "Warm water" means an aquatic venue with a water temperature over 90°F (32°C).
- 18 (63) Water recreational attraction.
- 19 (a) "Water recreational attraction" means special water circulation and operational features or  
20 unconventional design and operational features which provide patrons recreational activity  
21 different from that associated with a conventional swimming pool.
- 22 (b) "Water recreational attraction" includes but is not limited to a:
- 23 (i) Piece of water play equipment;
- 24 (ii) Lazy river;
- 25 (iii) Tube ride;
- 26 (iv) Water slide; and
- 27 (v) Wave pool.

## Draft Regulations for COMAR 10.17.01 – Aquatic Facilities and Venues

1 (c) "Water recreational attraction" does not include a spray ground, a floating or temporarily  
2 attached volleyball net, or a floating or temporarily attached basketball hoop.

3 (64) "Water slide" means a water-contact amusement ride when the height of the slide is 10 feet  
4 or more.

5 (65) "Wave pool" means a pool designed with mechanical or hydraulic apparatus to generate  
6 waves in the pool.

**Summary of changes:** Moves all definitions to one chapter rather than distributed throughout regulations.

**MAHC:** (21) "Lifeguard" is defined in Chapter 6.2.1, which describes the content, delivery, and certification for a training course.

**Relevant comments:**

• 2015-001	2015-030	2015-049	2015-064	2015-065	2015-066
• 2015-067	2015-068	2015-069	2015-070	2015-071	2015-072
• 2017-001	2017-002	2017-003	2017-004	2017-005	2017-006
• 2017-007	2017-067	2017-068	2017-069	2017-070	2017-071
• 2017-072	2017-083	2017-138	2017-139	2017-140	2017-165
• 2017-166	2017-167	2017-168	2017-169	2017-170	2017-171
• 2017-172	2017-173	2017-174	2017-175	2017-176	2017-177
• 2017-178	2017-179	2017-180	2017-181	2017-182	

7 (66) "WRI" means water replacement interval.

8 **.05 [Definitions.**

9 A. In this chapter, the following terms have the meanings indicated.

10 B. Terms Defined.

11 (1) Alteration.

12 (a) "Alteration" means to:

13 (i) Change or modify an equipment room, a bathhouse, a component, or the configuration of a  
14 pool or spa;

15 (ii) Move a component from one location or position to another; or

## Draft Regulations for COMAR 10.17.01 – Aquatic Facilities and Venues

- 1 (iii) Install a new component.
- 2 (b) "Alteration" does not include a repair or replacement.
- 3 (2) "Approved" means found by the Secretary to be in satisfactory compliance with applicable  
4 statutes and regulations promulgated or enforced by the Secretary.
- 5 (3) "Barrier" means a fence or wall or a combination of a fence and wall that completely  
6 surrounds and obstructs access to the pool or spa.
- 7 (4) "Cfm" means cubic feet per minute.
- 8 (4-1) "Component" means:
  - 9 (a) A piece of pool or spa equipment;
  - 10 (b) A deck;
  - 11 (c) A barrier;
  - 12 (d) One or more skimmers;
  - 13 (e) One or more filters, including piping and valves;
  - 14 (f) A ventilation system;
  - 15 (g) Lighting provided for water, deck, and walkways; or
  - 16 (h) Pipe material for pool or spa water.
- 17 (5) "Gpm" means gallons per minute.
- 18 (6) "Lifeguard" means an individual who is 15 years old or older and who has a valid lifeguard  
19 certificate from:
  - 20 (a) The American Red Cross;
  - 21 (b) The Boy Scouts of America, not including a lifeguard merit badge;
  - 22 (c) The Young Men's Christian Association;
  - 23 (d) Ellis and Associates' National Pool and Waterpark Lifeguard Training; or
  - 24 (e) An organization with a lifesaving training program equivalent to that of the American Red  
25 Cross.

## Draft Regulations for COMAR 10.17.01 – Aquatic Facilities and Venues

- 1 (7) Limited Public-Use Pool.
- 2 (a) "Limited public-use pool" means a private pool which is made available for use by:
- 3 (i) Children in family day care under the care of a family day care provider at a family day care  
4 home as defined in COMAR 07.04.01; or
- 5 (ii) An organized group, agency, or other person for swimming lessons or water safety training.
- 6 (b) "Limited public-use pool" does not include a pool that is emptied of water, disinfected, and  
7 refilled with water between each use.
- 8 (8) "Make-up water" means the potable water used to maintain the water level in a pool or a spa.
- 9 (9) "NSF" means the National Sanitation Foundation International.
- 10 (10) "NSPI" means the National Spa and Pool Institute.
- 11 (11) "Operator" means a person who supervises, controls, conducts, or manages the operation of  
12 a pool or spa.
- 13 (12) "Owner" means a person who has a legal interest in a pool or a spa or in the property on  
14 which a pool or a spa is or is to be constructed or altered, or the owner's agent.
- 15 (13) "Person" means an individual, receiver, trustee, guardian, personal representative, fiduciary,  
16 or representative of any kind and any partnership, firm, association, corporation, or other entity.
- 17 (14) "PHMB" means polyiminoimidocarbonyliminoimidocarbonyliminohexamethylene  
18 hydrochloride.
- 19 (15) "Pool" means an artificial enclosure of water that is used for the immersion of the human  
20 body for recreation, therapy, or exercise, including a structure that is installed in the ground,  
21 above ground, outside, or in a building or portable structure.
- 22 (16) "Ppm" means parts per million.
- 23 (17) Private Pool and Private Spa.
- 24 (a) "Private pool" and "private spa" mean a pool or spa that is:
- 25 (i) Not open to the public;
- 26 (ii) On a property on which not more than four private residences are located; and
- 27 (iii) Used exclusively by the residents of the property and nonpaying individuals invited to use  
28 the pool or spa by a resident.



## Draft Regulations for COMAR 10.17.01 – Aquatic Facilities and Venues

1 (b) "Private pool" and "private spa" include a pool or spa at a private residence used for short-  
2 term rentals including weekly, monthly, or seasonal rentals.

3 (18) Public Pool and Public Spa.

4 (a) "Public pool" and "public spa" mean a pool or spa that is not a private pool or spa.

5 (b) "Public pool" includes a:

6 (i) Limited public-use pools as defined in §B(7) of this regulation;

7 (ii) Recreational pool as defined in §B(19) of this regulation; and

8 (iii) Semipublic pool, as defined in §B(23) of this regulation.

9 (c) "Public spa" includes a semipublic spa, as defined in §B(23) of this regulation.

10 (19) "Recreational pool" means a pool that:

11 (a) Is not a limited public-use pool, private pool, or semipublic pool, as defined in §B(7), (17),  
12 and (23) of this regulation;

13 (b) Is provided as the owner's primary business or the facility's primary purpose, for example, a  
14 swim club or similar facility;

15 (c) Is open for general admission to the public;

16 (d) Is available to an individual paying a fee for use of the pool;

17 (e) Is equipped with a sliding board, diving platform, water slide, water flume, or water  
18 recreational play equipment that is built into or attached to the pool structure;

19 (f) Is provided by, or used by a:

20 (i) Youth camp;

21 (ii) College, university, or school;

22 (iii) Municipality;

23 (iv) Water park, amusement park, or water recreational attraction as defined in §B(34) of this  
24 regulation; or

25 (v) An apartment complex, housing subdivision, or mobile home park with more than ten units,  
26 except as provided in §B(23)(a)(v) of this regulation; or

## Draft Regulations for COMAR 10.17.01 – Aquatic Facilities and Venues

1 (g) Is used more than 4 times a week for swimming lessons, water safety instruction, or  
2 swimming competition.

3 (20) Repair.

4 (a) “Repair” means substituting a component having the same make and model as the previously  
5 approved component for the previously approved component.

6 (b) “Repair” does not include:

7 (i) Replacements;

8 (ii) Alterations;

9 (iii) Installation of additional equipment; or

10 (iv) Substitutions involving a component which do not meet the requirements of this chapter.

11 (20-1) Replacement.

12 (a) “Replacement” means substituting a component, which has a different make or model but has  
13 the same operating characteristics and certifications as the previously approved component, for  
14 the previously approved component.

15 (b) “Replacement” does not include:

16 (i) Repairs;

17 (ii) Substitutions involving a pump;

18 (iii) Substitutions involving a suction outlet sump or cover;

19 (iv) Alterations;

20 (v) Installation of additional equipment; or

21 (vi) Substitutions involving a component which do not meet the requirements of this chapter.

22 (21) "Safety vacuum release system" means a vacuum release system that:

23 (a) Is capable of providing vacuum release at a suction outlet caused by a high vacuum  
24 occurrence due to a suction outlet flow blockage; and

25 (b) Complies with 15 U.S.C. §8003.

## Draft Regulations for COMAR 10.17.01 – Aquatic Facilities and Venues

- 1 (22) "Secretary" means the Secretary of Health and Mental Hygiene or the Secretary's designee,  
2 including a local health officer.
- 3 (23) "Semipublic pool" and "semipublic spa" mean a pool or spa at a facility that:
- 4 (a) Has pool use or spa use restricted to an individual:
- 5 (i) Staying at the facility, where the facility is a temporary dwelling, including a hotel, motel,  
6 campground, bed and breakfast having nine or more guest rooms, or similar temporary dwelling;
- 7 (ii) Holding membership at the facility, where the facility is an adult health club, retirement  
8 community, marina, condominium, or similar facility;
- 9 (iii) Residing at an apartment complex, housing subdivision, or mobile home park with ten units  
10 or less;
- 11 (iv) Receiving treatment at a physical therapy center pool, or spa, where the pool or spa is used  
12 for providing therapy; or
- 13 (v) Who is the owner or an owner of the pool or spa; and
- 14 (b) Has a pool or spa that is not:
- 15 (i) Open for admission to the general public, except as provided in §B(23)(a) of this regulation;
- 16 (ii) Available to an individual upon the payment of a fee for the use of the pool and spa;
- 17 (iii) A limited public-use pool, a private pool, a private spa, or a recreational pool, as defined in  
18 §B(7), (17), and (18) of this regulation;
- 19 (iv) Equipped with a sliding board, diving platform, water slide, water flume, or water  
20 recreational play equipment that is built into or attached to the pool structure; and
- 21 (v) At a bed and breakfast that has eight or fewer guest rooms.
- 22 (24) "Shallow" means 5 feet or less in depth.
- 23 (25) "Spa" means a pool, hot tub, or whirlpool that is:
- 24 (a) Primarily designed for relaxation or therapeutic use and not for swimming;
- 25 (b) Not more than 4 feet in depth;
- 26 (c) Equipped with built-in seats or benches; and

## Draft Regulations for COMAR 10.17.01 – Aquatic Facilities and Venues

- 1 (d) Usually equipped with hydrotherapy jets, heated water, an air injection system, or some  
2 combination of these features.
- 3 (26) "Spray pool" means a shallow pool into which treated water is sprayed but not allowed to  
4 accumulate.
- 5 (27) "Swimming pool slide" means a device less than 10 feet in height that an individual may use  
6 to enter a pool by sliding down an inclined plane.
- 7 (28) "Swim spa" means a spa designed to create a current of water against which an individual  
8 may swim for exercise or therapy.
- 9 (29) "Therapy pool" means a pool that is exclusively used in the physical treatment of a disease,  
10 injury, or disorder.
- 11 (30) "Total dynamic head" means the hydraulic calculation of the resistance to flow in a  
12 circulation system based on the Hazen-Williams formula in Regulation .25C(1)(a) of this  
13 chapter.
- 14 (31) "Tube ride" means a pool designed to move an individual on a tube, raft, or other floating  
15 support along a channel filled with water.
- 16 (32) "Turnover rate" means the time required to circulate a quantity of water equal to the pool or  
17 spa volume.
- 18 (33) "Unblockable drain" means a drain of any size and shape that:
- 19 (a) A human body cannot sufficiently block to create a suction entrapment hazard;
- 20 (b) Has the minimum dimensions of 18 inches by 23 inches; and
- 21 (34) "User load" means the maximum number of individuals allowed in a pool or spa, as  
22 determined by the Secretary, for sanitary purposes, based on the water surface area and water  
23 depths.
- 24 (35) "Wading pool" means a pool with a water depth of 24 inches or less that is intended for use  
25 by children.
- 26 (36) Water Recreational Attraction.
- 27 (a) "Water recreational attraction" means a pool with special water circulation and operational  
28 features or unconventional design and operational features which provide patron recreational  
29 activity different from that associated with a conventional swimming pool, and which  
30 purposefully involves total or partial immersion in the water.
- 31 (b) "Water recreational attraction" includes but is not limited to a:

Draft Regulations for COMAR 10.17.01 – Aquatic Facilities and Venues

- 1 (i) Shallow water pool with permanently installed water play equipment;
- 2 (ii) Spray pool;
- 3 (iii) Tube ride;
- 4 (iv) Water slide; and
- 5 (v) Wave pool.

6 (c) "Water recreational attraction" does not include a pool with limited water features such as a  
7 deck-mounted sliding board or a raindrop feature.

8 (37) "Water slide" means a water-contact amusement ride when the height of the slide is 10 feet  
9 or more.

10 (38) "Wave pool" means a pool designed with mechanical or hydraulic apparatus to generate  
11 waves in the pool.]

12 ***Previously Constructed Aquatic Facilities and Venues.***

13 *A. The owner of an aquatic facility or venue that was constructed before February 10, 1997:*

14 *(1) Except as provided in §A(2)(b) and (4) of this regulation, is exempt from bringing an aquatic*  
15 *facility and venue into compliance with Regulations .13C, .14A(3), .16G(1), .16G(2)(a)-(b),*  
16 *.17C, .18A(3), .22, .22-1, .23B(3)-(4), .24, .25B, .26H(1)(a), .33, and .35 of this chapter;*

17 *(2) Shall:*

18 *(a) Except as required by §§A(2)(b)-(c) of this regulation, maintain an aquatic facility and venue*  
19 *as originally constructed;*

20 *(b) Ensure that a condition that jeopardizes the health or safety of the public is corrected to meet*  
21 *the requirements of this chapter; and*

22 *(c) Maintain the minimum turnover rate for the aquatic venue in compliance with §C of this*  
23 *regulation;*

24 *(3) May complete a repair according to Regulation .06-2 that restores an aquatic facility and*  
25 *venue to its original condition before damage or deterioration without the component complying*  
26 *with the requirements of this chapter;*

27 *(4) Who intends to alter an aquatic facility or venue shall ensure that the alteration complies*  
28 *with the requirements of this chapter; and*

Draft Regulations for COMAR 10.17.01 – Aquatic Facilities and Venues

1 (5) Notwithstanding any exemption set forth at §A(1) of this regulation, the diving area  
 2 dimensions shall comply with Regulation .27B of this chapter.

3 B. The owner of an aquatic facility or venue that received approval after construction from the  
 4 Secretary between February 10, 1997 and May 30, 2016:

5 (1) Except as provided in §B(2)(b) and (3) of this regulation, is exempt from bringing an aquatic  
 6 facility and venue into compliance with Regulations .16G(1) and (2)(a) and (b), .18-1B and C,  
 7 .22A(2)(b), .22-1, .22-2, .23B(3)-(4), .25B and D(4), .26H(1)(a), .33, and .35A(2)(a) of this  
 8 chapter;

9 (2) Shall:

10 (a) Maintain an aquatic facility and venue as originally constructed with regards to the  
 11 exemptions as set forth in §B(1) of this regulation;

12 (b) Ensure that a condition that jeopardizes the health or safety of the public is corrected to meet  
 13 the requirements of this chapter;

14 (c) Maintain the minimum turnover rate for the aquatic venue in compliance with §C of this  
 15 regulation;

16 (d) By January 1, 2017, bring an aquatic facility and venue into compliance with Regulations  
 17 .14C(2)(a) and (b), .19C(3), .21D, .24 .26I, and .40F(10) of this chapter; and

18  
 19 (e) By January 1, 2018, bring an aquatic facility and venue into compliance with Regulations  
 20 .23B(5) and (7), .26D, F(4),G(2)-(12), .29B(1) and (2), .40B(2), and .42 of this chapter; and

21 (3) Who intends to alter an aquatic facility or venue shall ensure that the alteration complies  
 22 with the requirements of this chapter.

23 C. The owner of an aquatic facility or venue that was constructed prior to February 10, 1997 or  
 24 that received construction approval from the Secretary between February 10, 1997 and May 30,  
 25 2016 shall maintain the following minimum turnover rates based on the aquatic venue type:

<i>Type of Aquatic Venue</i>	<i>Minimum Turnover Time (t)</i>
<i>Any Aquatic Venue Not Specifically Listed</i>	<i>480 minutes</i>
<i>Limited Public-Use Pool</i>	<i>720 minutes</i>
<i>Spa</i>	<i>30 minutes</i>
<i>Spray Ground</i>	<i>120 minutes</i>
<i>Therapy Pool</i>	<i>360 minutes</i>
<i>Wading Pool</i>	<i>120 minutes</i>
<i>Water Recreational Attraction</i>	<i>360 minutes</i>

26

## Draft Regulations for COMAR 10.17.01 – Aquatic Facilities and Venues

### Summary of changes:

Exempts existing pools from complying with certain regulations, depending on whether the pool was built prior to or after February 10, 1997. Establishes a minimum turnover rate for various types of existing aquatic facilities. Establishes a phase-in period for compliance with certain regulations for aquatic venues built after February 10, 1997.

### MAHC:

The MAHC lists key recommendations for existing facilities, but as a guideline, it does not explicitly exempt existing facilities from specific provisions. Key recommendations cover the following topics:

- Recirculation Systems and Filtration
- Hygiene Facilities
- Disinfection and Water Quality
- Facility Maintenance and Operation
- Operator Training
- Lifeguard/Bather Supervision
- Risk Management/Safety

### Relevant comments:

- 2015-002
- 2015-050
- 2017-008
- 2017-073
- 2017-084
- 2017-085
- 2017-086
- 2017-141
- 2017-142
- 2017-183
- 2017-184

1 **.06 Construction[, Alteration, and Replacement Permits for Recreational Pools, Semipublic**  
2 **Pools, and Public Spas] and Alteration Permits.**

3 A. An owner who intends to construct or alter [a recreational pool, semipublic pool, or public spa  
4 or replace a public pool or spa component shall obtain a construction, alteration, or replacement  
5 permit from the Secretary before beginning construction, alteration, or replacement work] *an*  
6 *aquatic facility or venue shall obtain a construction or alteration permit from the Secretary*  
7 *before beginning construction or alteration.*

8 B. An owner may not construct or alter [a recreational pool, semipublic pool, or public spa or  
9 replace a public pool or spa component] *an aquatic facility or venue* without a construction[,] *or*  
10 alteration[, or replacement] permit.

## Draft Regulations for COMAR 10.17.01 – Aquatic Facilities and Venues

1 C. To obtain a construction[, ] *or* alteration[, or replacement] permit, an owner shall submit to the  
2 Secretary:

3 (1) An application for a construction[, ] *or* alteration[, or replacement] permit on an application  
4 form provided by the Secretary that includes:

5 (a) The full names and addresses of the owner and authorized agents of the owner who may act  
6 on the owner’s behalf during the construction or alteration of [the pool or spa, or the replacement  
7 of the public pool or spa component] *an aquatic facility or venue*;

8 (b) A statement saying “I hereby acknowledge that all items either listed or shown in these plans  
9 and specifications as not in contract, by others, or equivalent, are my responsibility. I also realize  
10 that this entire project must be completed in accordance with the approved plans and  
11 specifications and all conditions listed in the construction[, ] *or* alteration[, or replacement]  
12 permit and meet the requirements of this chapter prior to the issuance of an operating permit by  
13 the Secretary”; and

14 (c) The owner’s signature, which:

15 (i) Indicates the owner has supplied the correct information on and with the application; and

16 (ii) Is in agreement with the statement set forth in [§C(1)(b)] §C of this regulation; [and]

17 (2) Plans and specifications for the construction[, ] *or* alteration[, or replacement] which:

18 (a) Are prepared by a licensed or certified professional engineer, architect, draftsman, or a person  
19 with extensive experience in the design of [pools and spas] *aquatic facilities and venues*;

20 (b) Are drawn to scale, in a professional and accurate manner, with sufficient clarity and detailed  
21 dimensions to show the nature and character of the work to be performed; [and]

22 (c) Include specific information on the quality or performance of the material or equipment when  
23 necessary to establish conformance with this chapter[.]; *and*

24 (d) *Are supplied in triplicate; and*

25 (3) *The application review fee required by COMAR 10.01.17.02.*

26 D. Except [for an alteration or replacement] *as provided in §E of this regulation*, an owner shall  
27 ensure that the plans and specifications required [in] by §C of this regulation include the  
28 following:

29 (1) Site plan with contours;

30 (2) Building plan;



## Draft Regulations for COMAR 10.17.01 – Aquatic Facilities and Venues

- 1 (3) [Pool or spa] *Aquatic venue* layout plan, sectional views, and appurtenant equipment;
- 2 (4) [Pool or spa] *Aquatic venue* piping layout plan;
- 3 (5) Deck and barrier plan;
- 4 (6) Filter room layout plan with the location of equipment and piping;
- 5 (7) Ventilation plan;
- 6 (8) Bathhouse plan;
- 7 (9) Lighting plan;
- 8 (10) Potable water supply plumbing diagram;
- 9 (11) Waste disposal plumbing diagram;
- 10 (12) Finish schedules;
- 11 (13) Equipment and material specifications;
- 12 (14) Head loss calculations;
- 13 (15) Pump performance curve;
- 14 (16) Waste water disposal site;
- 15 (17) Chemical storage plan; and
- 16 (18) Any information, including material samples, necessary to determine if the plans and  
17 specifications comply with criteria set forth in this chapter.
- 18 E. An owner shall ensure that, for an alteration [or, replacement,] *or partial construction*, the  
19 plans and specifications required [in] *by* §C of this regulation include the information that  
20 pertains to the alteration [or, replacement] *or partial construction*.
- 21 F. An owner shall obtain necessary local zoning approval and building, electrical, plumbing, and  
22 other applicable local permits before beginning construction [or alteration of a recreational pool,  
23 semipublic pool, or public spa or replacement of a public pool or spa component], *partial*  
24 *construction, or alteration work*.
- 25 G. [Before issuing a construction, alteration, or replacement permit, the Secretary may require  
26 changes in the design of the facilities if the design does not meet the criteria set forth in this  
27 chapter.

## Draft Regulations for COMAR 10.17.01 – Aquatic Facilities and Venues

1 H. Upon an owner's compliance with the provisions of this chapter, the Secretary shall approve  
2 the plans and specifications and issue a construction, alteration, or replacement permit, which is  
3 valid for the start of the construction, alteration, or replacement for 1 year from the date of issue  
4 and for 1 additional year from the date construction, alteration, or replacement begins.

5 I.] The local health department may not approve a local building permit for *or that includes*  
6 [recreational pool, semipublic pool, or public spa] construction, *partial construction, or*  
7 alteration [, or replacement] *of an aquatic facility or venue* until the plans and specifications for  
8 [pool or spa] construction, *partial construction, or alteration*[, or the replacement of a public pool  
9 or spa component] *of an aquatic facility or venue* have been approved by the Secretary.

10 [J.] H. The Secretary shall review the plans and application [and shall approve or deny issuance  
11 of] *for a construction, partial construction, or alteration*[, or replacement] permit within 30  
12 *business days* of receipt of the application.

13 [K.] I. If plans are submitted that are [not]:

14 (1) *Not in compliance with the requirements of this chapter, the Secretary shall [disapprove the*  
15 *plans and deny the issuance of a construction, alteration or replacement permit.]:*

16 (a) *Notify the owner of the deficiencies in the application;*

17 (b) *Deny the application if additional information to correct the deficiencies in the application*  
18 *are not received during the resubmittal window; or*

19 (c) *Allow the owner a resubmittal window of 30 calendar days to submit information to correct*  
20 *the deficiencies before denying the application according to §I of this regulation; and*

21 (2) *In compliance with the requirements of this chapter, the Secretary shall approve the plans*  
22 *and issue a construction, partial construction, or alteration permit, which is valid for the start of*  
23 *the construction, partial construction, or alteration for 1 year from the date of issue and for 1*  
24 *additional year from the date construction, partial construction, or alteration begins.*

25 J. *If the Secretary denies the issuance of a construction, partial construction, or alteration*  
26 *permit, an owner shall reapply for a new construction, partial construction, or alteration permit*  
27 *according to §C of this regulation and pay the applicable fees.*

28 [L] K. An owner may not deviate from the approved plans and specifications for construction,  
29 *partial construction, or alteration*[, or replacement at a recreational pool, semipublic pool, or  
30 public spa]*of an aquatic facility or venue* unless revised plans are submitted [to and approved in  
31 writing by the Secretary] *through the application review process in §C of this regulation, the*  
32 *owner pays the applicable fees, and the Secretary issues a construction, partial construction, or*  
33 *alteration permit for the revised work.*

34 [M] L. If [a recreational pool, semipublic pool, or public spa] *an aquatic facility or venue* is not  
35 being constructed, *partially constructed, or altered* [or components are not being replaced] in

## Draft Regulations for COMAR 10.17.01 – Aquatic Facilities and Venues

1 accordance with the approved plans, the Secretary may revoke the construction, *partial*  
2 *construction, or* alteration[, or replacement permit for the construction, alteration, or  
3 replacement] *permit* and the owner *shall* immediately [shall] cease construction, *partial*  
4 *construction, or* alteration[, or replacement].

5 [N] *M.* If the Secretary denies the issuance of a construction, *partial construction, or* alteration[,  
6 or replacement] permit as set forth in [§K]§I of this regulation, or revokes a construction, *partial*  
7 *construction, or* alteration[, or replacement] permit as set forth in [§M]§L of this regulation, the  
8 Secretary shall notify the owner in writing:

9 (1) Of the reason or reasons for the denial or revocation;

10 (2) That the owner may request from the Secretary an opportunity for a hearing on the denial or  
11 revocation pursuant to State Government Article, Title 10, Subtitle 2, Annotated Code of  
12 Maryland, if the owner wishes to contest the denial or revocation; and

13 (3) That to preserve the right to a hearing, the owner shall contact the Department within [30]10  
14 *calendar* days of the receipt of the notice of denial or revocation.

15 [O] *N.* An owner shall ensure that a construction, *partial construction, or* alteration[, or  
16 replacement] permit is posted in a conspicuous location at the site of construction, *partial*  
17 *construction, or* alteration[, or replacement].

18 [P. An owner may make a repair to a previously approved structure, component, or piece of  
19 equipment in accordance with this chapter without:

20 (1) Obtaining a construction, alteration or replacement permit from the Secretary; or

21 (2) Notifying the Secretary.]

### Summary of changes:

**MAHC:** Chapter 4.1 of the MAHC includes information required for the submission of an aquatic facility plan and may be applicable to section .06(C).

### Relevant comments:

- 2015-051
- 2015-073
- 2015-074
- 2015-075
- 2017-009
- 2017-185
- 2017-186
- 2017-187

Draft Regulations for COMAR 10.17.01 – Aquatic Facilities and Venues

1 **.06-1 Replacements.**

2 *A. An owner may replace a component at an aquatic facility or venue prior to obtaining*  
3 *approval from the Secretary.*

4 *B. An owner shall obtain necessary local zoning approval and building, electrical, plumbing,*  
5 *and other applicable local permits before replacing a component at an aquatic facility or venue.*

6 *C. The local health department may approve a local building permit for or that includes*  
7 *replacement of a component at an aquatic facility or venue before the replacement application is*  
8 *approved by the Secretary.*

9 *D. An owner shall submit, on a form provided by the Secretary, an application for the*  
10 *replacement of a component at an aquatic facility or venue within 10 calendar days of*  
11 *completing the replacement.*

12 *E. The Secretary shall inspect the replacement of a component at an aquatic facility or venue*  
13 *within 30 business days of receipt of the application.*

14 *F. If, during the inspection, the replacement of a component at an aquatic facility or venue is:*

15 *(1) In compliance with the requirements of this chapter, the Secretary shall;*

16 *(a) Provide the owner a copy of the inspection report; and*

17 *(b) Issue an approval letter; or*

18 *(2) Not in compliance with the requirements of this chapter, the Secretary shall:*

19 *(a) Deny the replacement application; and*

20 *(b) Notify the owner:*

21 *(i) Of the reason or reasons for the denial;*

22 *(ii) That the owner may request from the Secretary an opportunity for a hearing on the denial*  
23 *pursuant to State Government Article, Title 10, Subtitle 2, Annotated Code of Maryland, if the*  
24 *owner wishes to contest the denial;*

25 *(iii) That to preserve the right to a hearing, the owner shall contact the Department within*  
26 *[30]10 calendar days of the receipt of the notice of denial; and*

## Draft Regulations for COMAR 10.17.01 – Aquatic Facilities and Venues

- 1 *(iv) That the owner shall cease operation of an aquatic facility or venue if the component is*  
2 *essential to operation or cease operation of the replaced component where the replacement of a*  
3 *component was found to violate this chapter until the violation is corrected, a new replacement*  
4 *application and applicable fee is submitted to the Secretary, and the Secretary inspects and*  
5 *approves the replacement of the component.*

### Summary of changes:

#### MAHC: Relevant comments:

- 2015-003
- 2015-052
- 2017-010
- 2017-188

### 6 **.06-2 Repairs.**

7 *A. An owner may make a repair to an aquatic facility or venue in accordance with this chapter*  
8 *without:*

- 9 *(1) Obtaining a construction, partial construction, alteration, or replacement permit from the*  
10 *Secretary; or*  
11 *(2) Notifying the Secretary.*

### Summary of changes:

#### MAHC: Relevant comments:

- 2017-011

### 12 **.07 [Permit for Construction of Part of a Recreational Pool, Semipublic Pool, or Public** 13 **Spa.] Partial Construction Permits.**

14 *A. An owner may request a partial construction permit for [construction of part of a recreational*  
15 *pool, semipublic pool, or public spa] an aquatic facility or venue by submitting to the Secretary[:*

16 *(1) A detailed written explanation of why construction plans for the entire pool or spa cannot be*  
17 *submitted; and*

18 *(2) Plans] plans, information, and statements as required [in] by Regulation .06 of this chapter*  
19 *that pertain to the construction of part of [a recreational pool, semipublic pool, or public spa] an*  
20 *aquatic facility or venue[;].*

## Draft Regulations for COMAR 10.17.01 – Aquatic Facilities and Venues

- 1 [(3) A site plan;
- 2 (4) Information regarding the proposed water supply and waste disposal system; and
- 3 (5) A signed statement indicating that the permit holder for construction of part of a recreational  
4 pool, semipublic pool, or public spa will be proceeding at the owner's risk without the assurance  
5 that a permit for the construction of the rest of the pool or spa will be granted.
- 6 B. Upon an owner's compliance with the provisions of this chapter and local codes, the Secretary  
7 shall approve the plans and issue a permit for construction of part of a recreational pool,  
8 semipublic pool, or public spa.
- 9 C. If a person submits plans for the construction of part of a recreational pool, semipublic pool,  
10 or public spa that are not in compliance with the provisions of this chapter, or if a local code  
11 prohibits the issuance of a permit for partial construction, the Secretary shall disapprove the  
12 plans and deny a permit for the construction in accordance with Regulation .06 of this chapter.
- 13 D.] B. A person may not operate [a recreational pool, semipublic pool, or public spa] *an aquatic*  
14 *facility or venue* until the entire project has been constructed and approved in accordance with  
15 Regulations [.06-----.09] .06—.09 of this chapter.

### Summary of changes:

#### MAHC: Relevant comments:

- 2015-004
- 2015-053

- 16 **.08 Approval After Construction, *Partial Construction, or Alteration*[, or Replacement].**
- 17 A. [After construction, alteration, or replacement of a component at a recreational pool,  
18 semipublic pool, or public spa is completed, the owner shall contact the Secretary for approval of  
19 the pool or spa within 30 days.
- 20 B.] A person may not operate or permit the use of [a recreational pool, semipublic pool, or public  
21 spa] *an aquatic facility or venue* that has not received written approval from the Secretary after  
22 its [alteration or construction] *construction, partial construction, or alteration*.
- 23 [C. A person may operate or permit the use of a recreational pool, semipublic pool, or public spa  
24 for 30 days after completing the replacement of a public pool or spa component without  
25 receiving a final inspection and written approval from the Secretary.
- 26 D.] B. The Secretary shall conduct an inspection [or inspections] to ensure that [a recreational  
27 pool, semipublic pool, or public spa] *an aquatic facility or venue* is constructed or altered[, or

## Draft Regulations for COMAR 10.17.01 – Aquatic Facilities and Venues

1 that a public pool or spa component is replaced] according to the approved plans and meets the  
2 requirements of this chapter, and shall:

3 (1) Grant written approval for [the pool or spa] *an aquatic facility or venue* if it was constructed,  
4 *partially constructed*, or altered[, or a public pool or spa component was replaced] according to  
5 the approved plans, *meets the requirements of this chapter*, and the owner has received local  
6 approval for any building, electrical, plumbing, or other work that requires a local permit; or

7 (2) Deny approval for [the pool or spa] *an aquatic facility or venue* if it was not constructed,  
8 *partially constructed*, or altered[, or a public pool or spa component was not replaced] according  
9 to the approved plans, *does not meet the requirements of this chapter*, or the owner has not  
10 received local approval for any building, electrical, plumbing, or other work that requires a local  
11 permit.

12 [E.] C. The Secretary shall grant written approval or deny approval of the completed  
13 construction, *partial construction, or alteration*[, or replacement of a public pool or spa  
14 component within 30 days of receipt of notice of completion from the owner] *of an aquatic*  
15 *facility or venue within 15 business days of inspecting*.

16 [F.] D. If minor items that do not affect the health or safety of the public need to be corrected, the  
17 Secretary may issue a partial approval for [the pool or spa] *an aquatic facility or venue* after  
18 construction[, alteration, or replacement of a public pool or spa component] pending full  
19 compliance according to the following conditions:

20 (1) The owner shall fully comply with this chapter by the end of the 30 *calendar* day period in  
21 order to obtain written approval of [the recreational pool, semipublic pool, or public spa] *an*  
22 *aquatic facility or venue*; and

23 (2) If at the end of the 30 *calendar* day period, the Secretary is unable to approve [the  
24 recreational pool, semipublic pool, or public spa] *an aquatic facility or venue* pursuant to [§C]  
25 §B of this regulation, the Secretary shall [disapprove the construction, or alteration] *disapprove*  
26 *the construction of an aquatic facility or venue*.

27 [G.] E. If the Secretary does not grant approval for [the pool or spa] *an aquatic facility or venue*  
28 after it is constructed, *partially constructed* or altered[, or a public pool or spa component is  
29 replaced,] the Secretary shall notify the owner in writing:

30 (1) Of the reason or reasons for the disapproval;

31 (2) That the person may request, from the Secretary, an opportunity for a hearing on the  
32 disapproval pursuant to State Government Article, Title 10, Subtitle 2, Annotated Code of  
33 Maryland[, if the person wishes to contest the disapproval]; [and]

34 (3) That to preserve the right to a hearing, the person shall [contact] *submit a written request for*  
35 *a hearing* to the Secretary within [30] *10 calendar* days of the receipt of the notice of  
36 disapproval[.]; *and*

## Draft Regulations for COMAR 10.17.01 – Aquatic Facilities and Venues

- 1 (4) *That the person shall submit a new plan review application and pay any applicable fees*  
2 *according to Regulation .06 of this chapter.*

### Summary of changes:

#### MAHC: Relevant comments:

- 2015-054
- 2017-012

### 3 **.09 Permits for Operation.**

4 A. A person may not operate [a public pool or spa] *an aquatic venue* without an annual operating  
5 permit, issued by the Secretary, except that in the case of [a pool or spa] *an aquatic venue* that  
6 has received a partial approval of construction [or alteration] pursuant to Regulation [.08E] *.08D*  
7 of this chapter, the Secretary may issue a [nontransferable] *nontransferable 30 calendar day*  
8 permit for the temporary operation of the [pool or spa] *aquatic venue*.

9 B. On an application form provided by the Secretary, [a person] *an owner* shall apply to the  
10 Secretary for [a] *an annual* permit to operate [a public pool or spa at least 30 days before the  
11 pool or spa is scheduled to open for use for the first time and 30 days before a previous permit  
12 expires.] *an aquatic venue for, whichever day is later:*

13 (1) *At least 30 calendar days before the aquatic venue is scheduled to open for the season; or*

14 (2) *Thirty calendar days before the previous permit expires.*

15 C. The Secretary shall:

16 (1) Issue, *for each aquatic venue*, a nontransferable permit to an owner whose [public pool or  
17 spa] *aquatic venue* is in compliance with this chapter *as verified by a full compliance inspection*  
18 *completed within the 12 months prior to the application for a permit to operate; and*

19 (2) When [a public pool or spa] *an aquatic venue* does not meet the requirements of this chapter,  
20 deny the permit within 30 *business* days by notifying the owner in writing:

21 (a) Of the reason or reasons for the denial[.];

22 (b) Of the action to be taken in order for the [pool or spa] *aquatic venue* to qualify for a  
23 permit[.];

24 (c) That the owner may request from the Secretary an opportunity for a hearing on this denial  
25 pursuant to State Government Article, Title 10, Subtitle 2, Annotated Code of Maryland[.]; and



## Draft Regulations for COMAR 10.17.01 – Aquatic Facilities and Venues

1 (d) That to preserve the right to a hearing, the person shall contact the Secretary within [30]10  
2 *calendar* days of the receipt of the notice of denial.

3 D. A person who operates [a public pool or spa] *an aquatic venue* shall post the operating permit  
4 in a conspicuous place [at the pool or spa site] *near the entrance to the aquatic venue*.

### Summary of changes:

#### MAHC:

#### Relevant comments:

- 2015-055
- 2017-013
- 2017-087
- 2017-189
- 2017-190

### 5 **.10 Suspension or Revocation of an Operating Permit.**

6 A. Suspension.

7 (1) The Secretary may:

8 (a) Suspend an operating permit if an owner or operator violates a requirement of this chapter;  
9 and

10 (b) Summarily suspend an operating permit and close [a public pool or spa] *an aquatic venue*  
11 when protection of the public health, safety, or welfare imperatively requires emergency action.

12 (2) The Secretary may summarily suspend an operating permit pursuant to §A(1) of this  
13 regulation for any [of the following:

14 (a) Residual disinfection levels in violation of Regulation .44 of this chapter;

15 (b) Sanitary water quality in violation of Regulation .48 of this chapter;

16 (c) Water pH in violation of Regulation .45A(1) of this chapter;

17 (d) Water clarity in violation of Regulation .45A(7) of this chapter;

18 (e) A malfunctioning or nonworking recirculation or disinfection system;

19 (f) A condition that may endanger the health and safety of an individual using a pool or spa, for  
20 example, a missing drain cover or other suction outlet entrapment hazard; and

## Draft Regulations for COMAR 10.17.01 – Aquatic Facilities and Venues

1 (g) A lifeguard has not been provided as required [in] by Regulation .40 of this chapter] *critical*  
2 *violation as defined in Regulation .04B of this chapter.*

3 (3) *The Secretary may reinstate an operating permit to an owner whose operating permit was*  
4 *suspended when the owner:*

5 (a) *Corrects the violation;*

6 (b) *Pays any applicable fees; and*

7 (c) *Complies with all applicable provisions of this chapter.*

8 B. *Revocation and Permitting After Revocation.*

9 (1) The Secretary may revoke a permit [upon a repeated violation] *for:*

10 (a) *Consecutive repeat violations of a requirement of this chapter[.]; or*

11 (b) *An owner whose operating permit was revoked within the past two years, upon determination*  
12 *that the owner is in violation of the same requirement of this chapter that resulted in the previous*  
13 *revocation; and*

14 (2) *The Secretary may issue an operating permit to an owner whose operating permit was*  
15 *revoked:*

16 (a) *After the 6 month waiting period from the date of revocation has expired; and*

17 (b) *When the owner:*

18 (i) *Corrects the violations;*

19 (ii) *Applies for an operating permit;*

20 (iii) *Pays any applicable fees; and*

21 (iv) *Complies with all applicable provisions of this chapter.*

22 C. *Hearing.*

23 (1) In the case of the summary suspension of a permit pursuant to §A(1)(b) of this regulation, the  
24 Secretary shall provide a person with written notice of the violation and an opportunity for a  
25 hearing pursuant to State Government Article, Title 10, Subtitle 2, Annotated Code of Maryland.

26 (2) In the case of a permit suspension pursuant to §A(1)(a) of this regulation or a permit  
27 revocation pursuant to §B of this regulation, before taking action against a person, the Secretary

## Draft Regulations for COMAR 10.17.01 – Aquatic Facilities and Venues

- 1 shall provide written notice of the facts that warrant the suspension or revocation and an
- 2 opportunity for a hearing before suspending or revoking the permit.
- 3 (3) To preserve a right to a hearing, a person shall contact the Secretary within [30]10 calendar

### Summary of changes:

#### MAHC:

#### Relevant comments:

- 2015-017
- 2015-031
- 2015-032
- 2015-033
- 2015-056
- 2015-102
- 2017-014
- 2017-015
- 2017-088
- 2017-089

4 days of the receipt of the notice.

### 5 **.11 Inspections and Right of Entry.**

6 A. The Secretary may enter, at a reasonable time, public or private property for *the purpose of*

7 inspecting and investigating conditions relative to the enforcement of this chapter.

8 B. A person may not deny or interfere with the Secretary's entry onto public or private property

9 to inspect or to take enforcement action pursuant to this chapter.

10 C. *The Secretary shall conduct:*

11 (1) *A full compliance inspection of the aquatic venue relative to the enforcement of this chapter*

12 *at least once every 12 months;*

13 (2) *Except as provided in §C(4) of this regulation, a full compliance or routine inspection of the*

14 *aquatic venue relative to the enforcement of this chapter at least once every 90 business days;*

15 (3) *For an aquatic venue that had a critical violation of this chapter on the previous inspection,*

16 *a full compliance or routine inspection of the aquatic venue relative to the enforcement of this*

17 *chapter at least once every 30 business days until the aquatic venue has no critical violations of*

18 *this chapter; and*

## Draft Regulations for COMAR 10.17.01 – Aquatic Facilities and Venues

- 1 (4) For an aquatic venue that had no critical violations on the three previous consecutive  
2 inspections, a full compliance inspection of the aquatic venue relative to the enforcement of this  
3 chapter at least once every 12 months.

### Summary of changes:

#### MAHC:

#### Relevant comments:

- 2015-017
- 2015-031
- 2015-032
- 2015-033
- 2015-056
- 2015-102
- 2017-017
- 2017-090
- 2017-191
- 2017-192
- 2017-193
- 2017-194
- 2017-195

### 4 **.12 Conflict of Regulations.**

5 An owner shall comply with:

6 A. The provision that establishes a [higher] *more stringent* standard for the promotion and  
7 protection of public health and safety if a provision of this chapter is in conflict with a local  
8 code, ordinance, statute, or other regulation; and

9 B. This chapter if there is a conflict between this chapter and the provisions of American  
10 National Standard for Public Swimming Pools or the American National Standard for Public  
11 Spas.

### Summary of changes:

#### MAHC:

#### Relevant comments:

None

### 12 **.13 Standards for Recreational and Semipublic Pools.**

## Draft Regulations for COMAR 10.17.01 – Aquatic Facilities and Venues

1 An owner shall ensure that [an existing, newly built, or altered]a recreational or semipublic pool  
2 is in compliance with:

3 A. This chapter;

4 B. Applicable State and local codes; and

5 C. The American National Standard for Public Swimming Pools.

### Summary of changes:

#### MAHC:

#### Relevant comments:

- 2017-018
- 2017-196

### 6 **.14 Standards for Public Spas.**

7 A. An owner shall ensure that [an existing, newly built, or altered] a public spa is in compliance  
8 with:

9 (1) This chapter;

10 (2) Applicable State and local codes; and

11 (3) The American National Standard for Public Spas.

12 B. An owner shall ensure that a swim spa has:

13 (1) Clearly identified controls for the swim jets; and

14 (2) A shut-off switch for the swim jets that is accessible from within the swim spa.

15 C. An owner shall ensure that a spa hydrojet circulation system:

16 (1) Is not connected to a spa filtration system; and

17 (2) Has a shut-off switch *located:*

18 (a) *Within sight of the spa; and*

19 (b) *At least 5 feet horizontally from the inside walls of the spa.*

### Summary of changes:

#### MAHC:

#### Relevant comments:

None

## Draft Regulations for COMAR 10.17.01 – Aquatic Facilities and Venues

### 1 **.15 Standards for Limited Public-Use Pools.**

2 A. An owner of a limited public-use pool shall ensure that:

3 (1) The construction of the pool is in compliance with:

4 (a) The American National Standard for Residential Inground Swimming Pools, if the pool is  
5 constructed in the ground or as a permanent structure in a building; or

6 (b) The American National Standard for Aboveground/Onground Residential Swimming Pools,  
7 if the pool is removable and located above ground or on ground;

8 (2) The barrier around the pool is in compliance with:

9 (a) [Appendix E of the] *The American National Standard for Residential Inground Swimming*  
10 *Pools (ANSI/APSP/ICC-5 2011)*, if the pool is used by a family day care home; or

11 (b) Local building codes, if the pool is donated for use by an organized group, agency, or other  
12 person for swimming lessons or water safety training;

13 (3) The pool and the operation of the pool are in compliance with Regulations [.01—.05] .01—  
14 .06-2, .09—.12, .15, .19—.20, .24, [.25B(3)].25B(1), .28, .31, .34, .37—.41, and .43—[.54].55 of  
15 this chapter;

16 (4) The circulation system includes a properly sized flow meter to indicate the rate of flow;

17 (5) The dimensions of a diving area are:

18 (a) In conformance with Regulation [.27B] .27A of this chapter; or

19 (b) If the diving area does not conform to Regulation [.27B] .27A, the diving equipment is  
20 restricted from use by temporary barriers or is removed;

21 (6) [A suction outlet is in compliance with Regulation .28 of this chapter to prevent suction  
22 entrapment;

23 (7)] The following safety equipment is immediately available:

24 (a) A first aid kit [as recommended by the American Red Cross;

25 (b) A mouth piece for CPR;

26 (c) Disposable latex plastic gloves;

27 (d)] *that complies with Regulation .40A of this chapter;*

## Draft Regulations for COMAR 10.17.01 – Aquatic Facilities and Venues

- 1 (b) A blood borne pathogen control kit that complies with Regulation .40A of this chapter;
- 2 (c) A light, strong rescue pole [with a rescue hook designed for lifesaving] that complies with  
3 Regulation .40A of this chapter;
- 4 [(e)] (d) A rescue tube for each lifeguard, if a lifeguard is on duty; and
- 5 [(f)] (e) A telephone for reaching 911 emergency service [and the telephone location posted with  
6 the:
- 7 (i) Name and phone number of the nearest available police, fire, and ambulance or rescue unit,  
8 (ii) Name of the facility or the name of the owner of the property where the pool is located, and  
9 (iii) Location of the pool] that complies with Regulation .40B of this chapter;
- 10 [(8)] (7) An individual certified in [cardiopulmonary resuscitation (CPR)] CPR for the  
11 professional rescuer and certified in first aid is on duty while the pool is in use;
- 12 [(9)] (8) Pool chemicals are used and stored in accordance with manufacturers' directions and the  
13 [material] safety data sheet for [a] the particular chemical; and
- 14 [(10)] (9) The pool has backflow protection:
- 15 (a) For a potable water supply, in conformance with COMAR 09.20.01[,]; and  
16 (b) For waste water, in conformance with COMAR 09.20.01.
- 17 B. An owner of a family day care home using a limited public-use pool shall ensure that water  
18 safety supervision is provided in compliance with COMAR [07.04.01.22] 13A.15.08.04.
- 19 C. An organized group, agency, or other person using a limited public-use pool for swimming  
20 lessons or water safety training shall ensure that water safety supervision is provided as follows:
- 21 (1) An individual certified as an American Red Cross Water Safety Instructor, or with an  
22 equivalent certification that has been approved by the Secretary, is on site to conduct swimming  
23 lessons or water safety training; and
- 24 (2) Aquatic rescue staff are on site as follows:
- 25 (a) An individual certified in American Red Cross Basic Water Rescue, or with equivalent  
26 certification as approved by the Secretary, for each ten bathers, or fraction of ten bathers, if the  
27 pool:
- 28 (i) Is no more than 3 1/2 feet in depth at the shallow end of the swimming area[,];

## Draft Regulations for COMAR 10.17.01 – Aquatic Facilities and Venues

- 1 (ii) Is no more than 5 feet in depth at the deepest point[.];
- 2 (iii) Has a rescue pole that can be practically used to reach beyond the midpoint of the pool and  
3 can be used within the pool enclosure without an obstruction, such as a wall or tall fencing, that  
4 restricts the use of the pole[.]; and
- 5 (iv) Has no diving board, sliding board, or recreational play equipment, or the equipment is  
6 blocked off to restrict use; or
- 7 (b) An individual certified in American Red Cross Lifeguarding, or with an equivalent  
8 certification as approved by the Secretary, for each 25 bathers, or fraction of 25 bathers, if the  
9 pool:
- 10 (i) Is more than 3 1/2 feet in depth at the shallow end of the swimming area[.];
- 11 (ii) Has an area more than 5 feet in depth at the deepest point[.];
- 12 (iii) Does not have a rescue pole that can be practically used to reach beyond the midpoint of the  
13 pool, or an obstruction, such as a wall or tall fencing, exists within the pool enclosure that  
14 restricts the use of the pole[.]; or
- 15 (iv) Has a diving board, a sliding board, or recreational play equipment that is not blocked off to  
16 restrict use.
- 17 D. This regulation does not prohibit an organized group, agency, or other person using a limited  
18 public-use pool for swimming lessons or water safety training from providing the portable safety  
19 equipment, aquatic safety personnel, pool operator, test kits, or other materials required for a  
20 limited public-use pool, to meet the requirements of this chapter.

### Summary of changes:

#### MAHC:

#### Relevant comments:

- 2017-197
- 2017-198
- 2017-199

### 21 **.16 Standards for Water Recreational Attractions.**

22 An owner shall ensure that:

23 A. A water recreational attraction:



## Draft Regulations for COMAR 10.17.01 – Aquatic Facilities and Venues

- 1 (1) Is designed to eliminate or minimize safety hazards such as entrapment, slipping, abrasions,  
2 cuts, falls, trip hazards, impact injury, and drowning;
- 3 (2) Is in compliance with applicable State and local codes and this chapter; and
- 4 (3) Has a communication system for use by supervisors, watchers, and lifeguards;
- 5 B. Plans for supervision, attendants, and lifeguards are submitted as part of the construction *or*  
6 *alteration* plans and include safety personnel at all potentially hazardous activity areas;
- 7 C. A swimming pool slide is in conformance with the American National Standard for Public  
8 Swimming Pools and has:
  - 9 (1) Attachments that firmly anchor the swimming pool slide;
  - 10 (2) At the end of the slide, a minimum water depth of:
    - 11 (a) 4 feet, or a water depth in conformance with the manufacturer's installation instructions, for a  
12 distance of 10 feet along the slide centerline for a swimming pool slide that does not slow an  
13 individual's entry into the water or that drops the individual into the water; or
    - 14 (b) 6 inches, or a water depth in conformance with the manufacturer's installation instructions,  
15 for a swimming pool slide designed to slow an individual to a near stop at the end of the slide;
  - 16 (3) A cushioned landing mat below the end of a swimming pool slide if there is a potential for  
17 impact or abrasion injury;
  - 18 (4) A centerline distance from the end of a slide to a wall, lifeline, transition point, centerline  
19 from another slide, or obstruction that eliminates the potential for an individual using the slide to  
20 strike a wall, lifeline, transition point, an individual using another slide, or an obstruction *or a*  
21 *centerline distance in conformance with the manufacturer's installation instructions;*
  - 22 (5) A minimum side distance of 4 feet from the centerline of a slide to a wall, lifeline, transition  
23 point, or obstruction *or a minimum side distance in conformance with the manufacturer's*  
24 *installation instructions;*
  - 25 (6) A design that eliminates the potential for an individual to strike the pool deck or coping while  
26 traveling down the swimming pool slide;
  - 27 (7) A slide end that extends beyond the pool wall, deck, and coping; and
  - 28 (8) A minimum side distance of 12 feet between the centerline of a slide and a diving board,  
29 diving platform, or starting block;
- 30 D. A water slide:

Draft Regulations for COMAR 10.17.01 – Aquatic Facilities and Venues

1 (1) Complies with the conditions set forth [at] *in* COMAR 09.12.63 as evidenced by written  
2 documentation from:

3 (a) The Department of Labor, Licensing, and Regulation; or

4 (b) If the water slide is not subject to regulation by the Department of Labor, Licensing, and  
5 Regulation, a registered professional engineer who certifies that the water slide meets the design  
6 criteria set forth at COMAR 09.12.63.07; and

7 (2) Exits to a [plunge] *splash* pool or slide runout *as defined in COMAR 09.12.63.02 or a plunge*  
8 *pool*;

9 E. A wave pool is provided with an emergency shut-off switch at each guard station;

10 F. A tube ride has designated entry and exit points;

11 G. [A spray pool has:

12 (1) A bottom that slopes from 1/4 inch per foot to 5/8 inch per foot to a drain with grate;

13 (2) No standing water; and

14 (3) No obstruction less than 4 feet in height;] *A lazy river:*

15 (1) *Does not have:*

16 (a) *Handrails, steps, stairs, or propulsion jets that protrude into the river; or*

17 (b) *Obstructions around the perimeter of the lazy river, such as bridges or landscaping, that*  
18 *impact lifeguarding, sight lines, or rescue operations;*

19 (2) *Has:*

20 (a) *A means of access and egress provided at 150 foot intervals around the lazy river;*

21 (b) *A handhold, meeting the requirements of Regulation .22-1 of this chapter, on at least one side*  
22 *of the lazy river for the entire perimeter of the river; and*

23 (c) *Inlets which are:*

24 (i) *Equipped with directional fittings;*

25 (ii) *Positioned behind a grate with a maximum mesh size of 1½ inches; or*

## Draft Regulations for COMAR 10.17.01 – Aquatic Facilities and Venues

1 *(iii) Plumbed to pumps connected to the same power source so that no one pump can be*  
2 *operated independently from the rest to ensure that all inlets have continuous flow through them*  
3 *while the lazy river is in operation;*

4 *(3) That incorporates a bridge which spans the river shall install the bridge so that the minimum*  
5 *clearance from any structure overhead to the:*

6 *(a) Bottom of the lazy river is seven feet; and*

7 *(b) Static water surface is four feet; and*

8 *(4) Using inlets complying with §G(2) of this regulation is allowed to operate if a pump that*  
9 *provides current to a lazy river is not running.*

10 H. [A single-lane pool used for swimming laps has:

11 (1) A minimum width of 7 1/2 feet; and

12 (2) A sign on the deck that reads, "Warning: No Diving—Shallow Water" if the water depth is 5  
13 feet or less;

14 I.] A decorative fountain or waterfall [installed in or] connected to a pool or spa *circulation*  
15 *system* does not create a health or safety hazard;

16 [J.] I. A spray fixture, fountain, piece of play equipment, bridge, ramp, stair, float, swing, or  
17 other recreational equipment located within a pool or spa:

18 (1) Is designed to eliminate or minimize safety hazards such as entrapment, concealment,  
19 slipping, abrasions, cuts, punctures, falls, trip hazards, impact injury, and drowning;

20 (2) Is limited to a shallow water area;

21 (3) Has a color that contrasts with the pool or spa so that the structure is highly visible;

22 (4) Has pipes or support columns that are at least 6 inches in diameter;

23 (5) Is provided with an overhead clearance of at least 7 feet from the pool floor and 4 feet from  
24 the water surface where a person may walk under the fixture;

25 (6) Is provided with recirculated, treated [pool] water for a spray, stream, or other flow of water;  
26 and

27 (7) Is installed according to the manufacturer's directions;

28 [K.] J. The water surface is maintained at a level that allows the surface overflow system to  
29 operate properly;

## Draft Regulations for COMAR 10.17.01 – Aquatic Facilities and Venues

- 1 [L. At least two interconnected main drains are installed in the deepest part of a pool and] *K. One*  
2 *or more suction outlet covers, meeting the requirements of Regulation .28 of this chapter, are*  
3 *connected to the filtration system;*
- 4 [M.] *L. A pump reservoir or surge tank is provided for a swimming pool slide [or], water feature,*  
5 *or water slide circulation pump intake and:*
- 6 (1) Is made of concrete or other impervious material with a smooth slip-resistant finish;
- 7 (2) Has inlets through a weir or a gravity-fed drain with a secure grate;
- 8 (3) Has a volume equal to 2 minutes of the combined flow of all pumps connected to the  
9 reservoir or tank;
- 10 (4) Is accessible only to authorized individuals;
- 11 (5) Has pump intakes located in the pump reservoir that are designed to allow cleaning without  
12 danger of entrapment; and
- 13 (6) The water velocity through grate or drain openings does not exceed 2 feet per second;
- 14 [N.] *M. A swimming pool slide, water slide or water feature circulation pump has a check valve*  
15 *on the discharge side; and*
- 16 [O. Returns] *N. A return from a filtration system [are] is placed to provide even and positive*  
17 *circulation and to eliminate any dead spots.*

### Summary of changes:

#### MAHC:

#### Relevant comments:

- 2015-034
- 2017-019
- 2017-091
- 2017-092
- 2017-200
- 2017-201
- 2017-202
- 2017-203
- 2017-204
- 2017-205
- 2017-206

### 18 **.17 Standards for Public Wading Pools.**

## Draft Regulations for COMAR 10.17.01 – Aquatic Facilities and Venues

- 1 An owner shall ensure that a public wading pool is in compliance with:
- 2 A. This chapter;
- 3 B. Applicable State and local codes; *and*
- 4 C. The American National Standard for Public Swimming Pools[; and
- 5 D. Article 10.6 of the American National Standard for Public Spas].

### Summary of changes:

#### MAHC:

#### Relevant comments:

- 2017-020

### 6 **.18 Standards for Public Therapy Pools.**

7 An owner shall ensure that a public therapy pool:

8 A. Is in compliance with:

- 9 (1) This chapter;
- 10 (2) Applicable State and local codes; and
- 11 (3) The American National Standard for Public Swimming Pools;

12 B. Has:

- 13 (1) A deck with a minimum width of 4 feet around at least 50 percent of the therapy pool that
- 14 provides access to individuals using the therapy pool, not including any ramp, entrance area, or
- 15 exercise area; and
- 16 (2) A transition area between a shallow and a deep area that has:
  - 17 (a) A floor slope that does not exceed 1 foot of drop to 3 feet of run; [or]
  - 18 (b) Steps [or ramps];
  - 19 (c) A *ramp* with handrails [or a];

## Draft Regulations for COMAR 10.17.01 – Aquatic Facilities and Venues

- 1 (d) A swing lift to transfer bathers from a shallow area to a deep area; [and] or
- 2 (e) A floor slope that exceeds 1 foot of drop to 3 feet of run that is equipped with a protective
- 3 barrier; and
- 4 C. Is used only for the purpose of supervised therapy.

### Summary of changes:

#### MAHC:

#### Relevant comments:

- 2017-021
- 2017-207

### 5 **.18-1 Standards for Spray Grounds.**

6 *An owner shall ensure that a spray ground:*

7 *A. Is in compliance with:*

8 *(1) This chapter; and*

9 *(2) Applicable State and local codes;*

10 *B. Except when it is within a barrier, is equipped with a mechanism for controlling the operation*  
11 *of a spray ground, which can be locked to prevent unauthorized use of the spray ground; and*

12 *C. Has a pump reservoir or surge tank provided for a spray ground circulation pump intake and:*

13 *(1) Is made of concrete or other impervious material with a smooth slip-resistant finish;*

14 *(2) Has inlets through a weir or a gravity-fed drain with a secure grate;*

15 *(3) Has a minimum volume equal to 2 minutes of the combined flow of all pumps connected to*  
16 *the reservoir or tank;*

17 *(4) Is accessible only to authorized individuals;*

18 *(5) Has pump intakes located in the pump reservoir that are designed to allow cleaning without*  
19 *danger of entrapment; and*

Draft Regulations for COMAR 10.17.01 – Aquatic Facilities and Venues

1 (6) *The water velocity through grate or drain openings does not exceed 2 feet per second.*

**Summary of changes:**

**MAHC:**

**Relevant comments:**

- 2017-022
- 2017-074
- 2017-093

2 **.19 User Load and Theoretical Peak Occupancy.**

3 A. The Secretary shall determine the user load, as defined in Regulation [.05B(32)] .04 of this  
4 chapter, *for each aquatic venue* based on the following criteria:

5 (1) For a pool [and its deck], one individual is allowed for:

6 (a) Every 12 square feet of water surface in shallow areas[.];

7 (b) Every 15 square feet of water surface in areas exceeding 5 feet of water depth, excluding a  
8 diving area[.]; and

9 (c) The 300 square-foot diving area required for each diving board or diving platform;

10 (2) For a spa, one individual is allowed for every 9 square feet of water surface; [and]

11 (3) For a therapy pool, one individual is allowed for every:

12 (a) Therapy station[.]; or

13 (b) 20 square feet of water surface, whichever is less[.]; *and*

14 (4) *For a spray ground, one individual is allowed for every 10 square feet of splash zone.*

15 B. *The Secretary shall determine the theoretical peak occupancy, as defined in Regulation .04 of*  
16 *this chapter, for an aquatic facility based on the density factors (D) for:*

17 (1) *Flat water: 20 square feet per individual;*

18 (2) *Agitated water: 15 square feet per individual;*

19 (3) *Warm water: 10 square feet per individual;*

20 (4) *Waterslide landing pool: the manufacturer-established capacity at any given time;*

## Draft Regulations for COMAR 10.17.01 – Aquatic Facilities and Venues

1 (5) *Spray ground: 10 square feet per individual;*

2 (6) *Deck: 50 square feet per individual; and*

3 (7) *Stadium seating: 6.6 square feet per individual.*

4 C. An owner shall ensure that the:

5 (1) Number of individuals [in a pool or spa and on the required deck area] *using an aquatic*  
6 *venue does not exceed the user load as set forth in §A of this regulation;*

7 (2) Number of individuals [using an enclosed pool or spa area or a spectator area] *using an*  
8 *aquatic facility is in conformance with the theoretical peak occupancy as set forth in §B of this*  
9 *regulation and local fire code requirements; and*

10 (3) User load [of a pool or spa is posted in a conspicuous place at the pool or spa] *for each*  
11 *aquatic venue is posted at the entrance to each aquatic facility or venue.*

### Summary of changes:

#### MAHC:

#### Relevant comments:

- 2015-006
- 2015-018
- 2015-077
- 2015-078
- 2015-103
- 2017-023
- 2017-062
- 2017-094
- 2017-208
- 2017-209

12 **.20 [Public Pool or Spa Site] Aquatic Venue Site.**

13 An owner shall ensure that [a public pool or spa] *an aquatic venue site:*

14 A. Drains away from the [pool or spa] *aquatic venue area;*

15 B. Has water and waste water facilities that conform to the requirements of:

16 (1) COMAR 09.20.01[.];

17 (2) COMAR [26.04.01-----26.04.04.] *26.04.01—26.04.04;* and



## Draft Regulations for COMAR 10.17.01 – Aquatic Facilities and Venues

- 1 (3) Local plumbing code requirements;
- 2 C. Has a walkway between [a pool or spa] *an aquatic venue* and appurtenant buildings such as a
- 3 bathhouse or equipment room; and
- 4 D. Complies with applicable State and local codes.

### Summary of changes:

#### MAHC:

#### Relevant comments:

- 2017-024
- 2017-095
- 2017-210

### 5 **.21 Barriers.**

6 A. Except as set forth in [§§B, C, and D] §§B—E of this regulation, an owner shall ensure that [a  
7 recreational pool, semipublic pool, or public spa,] *an aquatic venue*, including the required deck  
8 area, is completely surrounded by a barrier that complies with the following requirements:

- 9 (1) The top of the barrier is at least 72 inches above grade measured on the side of the barrier that  
10 faces away from the [pool or spa] *aquatic venue*;
- 11 (2) The maximum vertical clearance between grade and the bottom of the barrier is 4 inches  
12 measured on the side of the barrier that faces away from the [pool or spa] *aquatic venue*;
- 13 (3) Except when the entrance gate is open, an opening in the barrier and in the gate does not  
14 allow passage of a sphere 4 inches in diameter;
- 15 (4) Fence pickets have a maximum separation of 4 inches;
- 16 (5) The barrier does not have openings or footholds that make the barrier easy to climb;
- 17 (6) A barrier with horizontal members less than 45 inches apart measured top to top does not  
18 have:
  - 19 (a) Vertical openings greater than 1-3/4 inches in width; and
  - 20 (b) Horizontal members on the outside of the barrier;
- 21 (7) The barrier does not have decorative cutouts greater than 1-3/4 inches in width;
- 22 (8) A chain link fence has a maximum mesh size of 2-1/4 inches;

Draft Regulations for COMAR 10.17.01 – Aquatic Facilities and Venues

- 1 (9) A lattice fence has a maximum mesh size of 1-3/4 inches;
- 2 (10) The barrier main access gate:
- 3 (a) Is located toward the shallow end of [a pool] *of the aquatic venue*;
- 4 (b) Has a latch release located at least 54 inches from grade level;
- 5 (c) Is [lockable]*locked when the aquatic venue is not open for use*;
- 6 (d) Is hung to open away from the [pool or spa] *aquatic venue*; and
- 7 (e) Has a minimum width of 4 feet; and
- 8 [(f) Complies with Regulation .37 of this chapter; and]
- 9 (11) Doors and windows that open into the [pool or spa] *aquatic venue* area enclosed by the
- 10 barrier have locks or latches to prevent unauthorized entry.
- 11 B. An owner shall ensure that a barrier at a semipublic pool or semipublic spa:
- 12 (1) Has a minimum height of 60 inches;
- 13 (2) Has a gate that is self-closing and self-latching; and
- 14 (3) Complies with the requirements in §A(2)—(11) of this regulation.
- 15 C. Except as provided in §D of this regulation, an owner may surround [a pool and spa, multiple
- 16 pools, or multiple spas] *an aquatic venue or multiple aquatic venues* at one facility with one
- 17 barrier instead of separate barriers for each [pool or spa] *aquatic venue*.
- 18 D. [An] *Except as provided by §§E—G of this regulation*, an owner shall ensure that a wading
- 19 pool *or a spray ground* [or infant pool is] *are* separated from [a pool or spa] *all other bodies of*
- 20 *water* by a barrier that has:
- 21 (1) A minimum height of 36 inches;
- 22 (2) A maximum 2-inch separation between the deck and the bottom of the barrier;
- 23 (3) No opening that allows the passage of a sphere 4 inches in diameter; [and
- 24 (4) An entrance gate with a latch.]
- 25 (4) *Has an entrance gate that is self-closing and self-latching that is hung to open toward the*
- 26 *wading pool or spray ground*; and

## Draft Regulations for COMAR 10.17.01 – Aquatic Facilities and Venues

1 (5) Except as provided in §A(10) of this regulation, complies with the requirements in §A(2)—  
2 (11).

3 E. An owner of a spray ground that is not part of an aquatic facility with a body of water is not  
4 required to provide a barrier.

5 F. An owner of a wading pool or spray ground is not required to separate the wading pool and  
6 spray ground with a barrier.

7 G. An owner of a spray ground that is part of an aquatic facility with a body of water is not  
8 required to provide a barrier if:

9 (1) An unobstructed path with a minimum horizontal distance of 30 feet is provided between the  
10 edge of the spray ground deck closest to the body of water and the water's edge closest to the  
11 spray ground; or

12 (2) An obstructed path with a minimum horizontal distance of 15 feet is provided between the  
13 edge of the spray ground deck closest to the body of water and the water's edge closest to the  
14 spray ground.

### Summary of changes:

#### MAHC:

#### Relevant comments:

- 2015-021
- 2017-025
- 2017-096
- 2017-211
- 2017-212
- 2017-213
- 2017-214

### 15 .22 Decks.

16 A. An owner shall ensure that:

17 (1) [A deck at a recreational or semipublic pool] A perimeter deck at a public pool or spray  
18 ground:

19 (a) [Completely surrounds] Surrounds at least 75 percent of the pool or spray ground perimeter;

20 (b) Is [continuous]:

Draft Regulations for COMAR 10.17.01 – Aquatic Facilities and Venues

1 (i) *Continuous*, with a minimum unobstructed width of 4 feet and an average width of 6 feet[.];  
2 and

3 [(c) Is in] (ii) *In conformance with the American National Standard for Public Swimming Pools;*  
4 *and*

5 (c) *Is not:*

6 (i) *Constructed of wood; and*

7 (ii) *More than 30 inches below the static water level;*

8 (2) A *perimeter* deck at a public spa is [in]:

9 (a) *In conformance with the American National Standard for Public Spas; and*

10 (b) *Not constructed of wood;*

11 (3) The slope of a deck is away from [a pool or a spa] *an aquatic venue*, toward points of  
12 disposal, and not less than [1/4] 3/16 inch per foot, or greater than 1/2 inch per foot;

13 (4) The deck has drainage to deck drains or other points of disposal *in compliance with COMAR*  
14 *26.04.02;*

15 (5) The deck's surface is slip resistant or nonskid;

16 (6) An expansion joint between the coping and deck is sealed with a durable, watertight sealant;

17 (7) A brick, stone, aggregate, or similar deck surface has a subdeck in the required deck area;

18 (8) A wood deck has a gravel and plastic ground barrier or a concrete subdeck in the required  
19 deck area; [and]

20 (9) The deck does not trap dirt or support [or harbor algae.] *the harborage of algae; and*

21 (10) *Carpet is not installed on the deck surface of the perimeter or pool deck.*

22 B. An owner may:

23 (1) Include the *deck level coping of a pool or spa* [coping] in the measurement of the deck width;  
24 and

25 (2) Have ladders, handrails, lifeguard stands, structures for use by disabled individuals, and other  
26 pool equipment on the deck.

## Draft Regulations for COMAR 10.17.01 – Aquatic Facilities and Venues

- 1 C. Except as provided in §B(2) of this regulation, an owner may not have light poles, structural  
2 supports, decorative fountains, waterfalls, and other obstacles or obstructions within 4 feet of a  
3 pool or within the required deck area of a spa *or spray ground*.
- 4 D. An owner shall ensure that an anchor for a fixture used to support a backstroke flag,  
5 volleyball net, or similar recreational equipment is fitted with a cap or plug that is flush with the  
6 deck when the anchor is not in use.

### Summary of changes:

#### MAHC:

#### Relevant comments:

- 2015-035
- 2017-097
- 2017-143
- 2017-215
- 2017-216
- 2017-217

### 7 *.22-1 Handholds.*

8 *A. An owner shall ensure that:*

9 *(1) A handhold is installed:*

10 *(a) Anytime the water depth of the aquatic venue exceeds 24 inches;*

11 *(b) Not greater than 9 inches above or 3 inches below the static water level of the aquatic venue;*  
12 *and*

13 *(c) Not greater than 2 inches or less than 1 inch from the vertical plane of the aquatic venue*  
14 *wall; and*

15 *(2) The thickness of the handhold does not exceed 3.5 inches for the last 2 inches of the*  
16 *overhang.*

### Summary of changes:

#### MAHC:

#### Relevant comments:

- 2015-035
- 2017-098
- 2017-218

## Draft Regulations for COMAR 10.17.01 – Aquatic Facilities and Venues

### 1 **.22-2 Infinity Edges.**

2 *A. An owner shall ensure that:*

3 *(1) The length of an infinity edge shall be no more than 30 feet long when in water depths*  
4 *greater than five feet;*

5 *(2) Handholds conforming to the requirements of Regulation .22-1 of this chapter are provided*  
6 *for infinity edges;*

7 *(3) Infinity edges are constructed of reinforced concrete or other impervious and structurally*  
8 *rigid material(s), and designed to withstand the loads imposed by pool water, bathers, and*  
9 *adjacent soils or structures;*

10 *(4) Troughs, basins, or capture drains designed to receive the overflow from infinity edges:*

11 *(a) Are watertight and free from structural cracks;*

12 *(b) Have a non-toxic, smooth, and slip-resistant finish; and*

13 *(c) Are equipped with grates;*

14 *(5) The maximum height of the wall outside of the infinity edge does not exceed 30 inches to the*  
15 *adjacent grade and capture drain; and*

16 *(6) The maximum length of the infinity edge does not exceed 50 percent of the perimeter of the*  
17 *pool.*

#### **Summary of changes:**

#### **MAHC:**

#### **Relevant comments:**

- 2015-007
- 2015-019
- 2015-020
- 2015-036
- 2015-043
- 2015-079
- 2015-080
- 2015-081
- 2015-104
- 2017-219

### 18 **.23 Equipment Rooms.**

## Draft Regulations for COMAR 10.17.01 – Aquatic Facilities and Venues

- 1 An owner shall ensure that [a recreational pool, semipublic pool, or public spa] *an aquatic venue*  
2 has an equipment room that:
- 3 A. [Houses the pool or spa] *Except when the manufacturer requires a piece of equipment to be*  
4 *outside the equipment room for proper operation, houses the aquatic venue* circulation, filtration,  
5 and disinfection equipment; and
- 6 B. Has:
- 7 (1) Weather tight construction to prevent the entrance of precipitation;
- 8 (2) Adequate floor area for safe access to all equipment;
- 9 (3) A minimum ceiling height of 7 feet 6 inches;
- 10 (4) [A waterproof floor that drains to a floor drain] *A floor:*
- 11 *(a) Constructed of concrete or other suitable material having a smooth slip resistant finish and a*  
12 *positive drainage, including a sump drain pump if necessary; and*
- 13 *(b) Sloped toward the floor drain or a sump drain pump adequate to prevent standing water at*  
14 *all times;*
- 15 (5) [A lockable entrance door that allows complete and unencumbered access to the equipment  
16 room;] *An entrance door that:*
- 17 *(a) Allows complete and unencumbered access to the equipment room;*
- 18 *(b) Is equipped with:*
- 19 *(i) An automatic closer;*
- 20 *(ii) An automatic lock; and*
- 21 *(iii) A lock that requires a key or combination to open from the outside;*
- 22 *(c) Is installed and maintained to ensure that the door closes completely and latches without*  
23 *human assistance; and*
- 24 *(d) Is designed and installed to be opened by one hand from the inside of the room under all*  
25 *circumstances, without the use of a key or tool;*
- 26 (6) A minimum of [20 foot-candles] *20 lumens* of artificial illumination *per square foot of floor*  
27 *space within the equipment room;*
- 28 (7) Ventilation sized at 2 cubic feet per minute per square foot of floor area that [is:

## Draft Regulations for COMAR 10.17.01 – Aquatic Facilities and Venues

- 1 (a) Mechanical] *has a continuous mechanical exhaust ventilation with the exhaust vent intake*  
2 *placed at a height less than or equal to 3 feet from the floor of the equipment room, discharged*  
3 *to limit exposure to the public [if chemicals are used or stored in the equipment room, or*
- 4 (b) Natural or mechanical exhaust ventilation if chemicals are not used or stored in the  
5 equipment room];
- 6 (8) Adequate make-up air to replace the air exhausted by the ventilation system;
- 7 (9) A hose bibb with an atmospheric vacuum breaker *or a hose bibb with an atmospheric*  
8 *vacuum breaker that is accessible within 50 feet of the equipment room so that a hose can*  
9 *service the entire equipment room; and*
- 10 (10) A water-resistant data sheet that is posted in a conspicuous place for each [pool or spa]  
11 *aquatic venue and includes the following information:*
- 12 (a) Volume of water[,] *in the pool, spa, or surge tank of a spray ground;*
- 13 (b) Minimum turnover rate[,] *in gpm;*
- 14 (c) Maximum filter capacity[,] *in gpm;*
- 15 (d) Water surface [area,] *or splash zone area in square feet;*
- 16 (e) [Length] *Except for a spray ground, the length of water perimeter[,] in feet;*
- 17 (f) Maximum [bather] *user load[, and];*
- 18 (g) Operating instructions for valves and equipment[.]; *and*
- 19 (h) *For aquatic venues that use salt chlorine generators, the total dissolved solids level in ppm*  
20 *once the minimum amount of salt has been added to an aquatic venue.*

### Summary of changes:

#### MAHC:

#### Relevant comments:

- 2017-026
- 2017-055
- 2017-099
- 2017-220
- 2017-221

### 21 **.24 Pipe Material And Identification.**



## Draft Regulations for COMAR 10.17.01 – Aquatic Facilities and Venues

- 1 An owner shall ensure that [pipe]:
- 2 A. *Pipe* material for [a public pool or spa] *an aquatic venue* conforms to COMAR 09.20.01[.];
- 3 B. *Identification is provided for main drains, skimmers, filtered water, make-up water, backwash*
- 4 *water, disinfection feeds, acid feeds, compressed air lines, gutters, chemical sample piping, and*
- 5 *heating lines;*
- 6 C. *All piping is marked with directional arrows to indicate flow direction during filtration; and*
- 7 D. *All valves are:*
- 8 (1) *Clearly identified by number with a brass tag, plastic laminate tag or permanently affixed*
- 9 *alternate; and*
- 10 (2) *Described as to their function and referenced in the operating instruction manual.*

### Summary of changes:

#### MAHC:

#### Relevant comments:

- 2015-105
- 2017-027
- 2017-100
- 2017-222

### 11 **.25 Circulation Systems.**

- 12 A. **Gauges and Release Valves.** An owner shall ensure that the circulation system for [a
- 13 recreational pool, semipublic pool, or public spa] *an aquatic venue* includes the following, a:
- 14 (1) [A pressure] *Pressure* gauge on [the] *each* filter or on the influent side of the filter piping;
- 15 (2) [A pressure] *Pressure* gauge on the effluent side of the filter piping;
- 16 (3) [A vacuum] *Vacuum* or compound gauge on the influent side of a pump;
- 17 (4) [A flow] *Flow* meter that:
- 18 (a) Indicates the rate of flow through the circulation system;
- 19 (b) Has a permanent scale readable in [gallons per minute] *gpm*;

Draft Regulations for COMAR 10.17.01 – Aquatic Facilities and Venues

- 1 (c) Is accurate to within 10 percent of the actual flow; and
- 2 (d) Reads in the range encompassing the minimum and maximum flow rate;
- 3 (5) [A thermometer] *Thermometer* on the return line to [a pool or spa] *an aquatic venue* if the
- 4 circulation system includes a heating system; and
- 5 (6) [A manually] *Manually* operated air release valve on a pressure filter or a separation tank, or
- 6 both.

7 B. Turnover Rate.

8 (1) An owner shall ensure that *an aquatic venue is constructed to produce a minimum turnover*  
9 *rate (volume of the aquatic venue divided by maximum turnover time (t)), with continuous 24*  
10 *hour flow using the values for (t) provided in the following table:*

11 [(1) A recreational pool, semipublic pool, or public spa is constructed to produce the following  
12 minimum turnover rates, with continuous 24-hour flow:

- 13 (a) Pools for swimming and diving: Minimum turnover rate = volume of pool in gallons/480  
14 minutes;
- 15 (b) Pools for water recreational attractions and therapy: Minimum turnover rate = volume of pool  
16 in gallons/360 minutes;
- 17 (c) Pools for wading have a minimum turnover rate equal to the greater of:
  - 18 (i) Volume of pool in gallons/120 minutes; or
  - 19 (ii) The minimum flow required for the skimmer system and main drain to operate according to  
20 the manufacturer's specifications; and
- 21 (d) Spas: Minimum turnover rate = volume of spa/30 minutes;

22 (2) The flow through a circulation system is maintained between the minimum turnover rate and  
23 the design capacity of the filter system and associated piping; and

24 (3) A limited public-use pool has a turnover rate in conformance with:

- 25 (a) American National Standard for Residential Inground Swimming Pools; or
- 26 (b) American National Standard for Aboveground/Onground Residential Swimming Pools.]

<i>Type of Aquatic Venue</i>	<i>Minimum Turnover Time (t)</i>
<i>Any Aquatic Venue Not Specifically Listed</i>	<i>360 minutes</i>
<i>Limited Public-Use Pool</i>	<i>720 minutes</i>

Draft Regulations for COMAR 10.17.01 – Aquatic Facilities and Venues

<i>Spa</i>	<i>30 minutes</i>
<i>Spray Ground</i>	<i>30 minutes</i>
<i>Therapy Pool</i>	<i>240 minutes</i>
<i>Wading Pool</i>	<i>60 minutes</i>
<i>Water Recreational Attraction</i>	<i>120 minutes</i>

1 C. Head Loss Calculations. An owner of [a recreational pool, semipublic pool, or public spa] *an*  
 2 *aquatic venue* shall ensure that head loss calculations include the following:

3 (1) Piping head loss, found by using:

4 (a) The Hazen-Williams formula which is: piping head loss per 100 feet of pipe =  $0.2083 (100 /$   
 5  $C)^{1.852} (Q^{1.852} / D^{4.865})$

6 where: D = nominal inside diameter of pipe;

7 Q = gpm;

8 C = constant for inside roughness of pipe; or

9 (b) Standard engineering tables;

10 (2) Equipment head loss, including filters, valves, heaters, and other circulation equipment,  
 11 based on the manufacturers' specifications for the equipment at the design flow rate, and filter  
 12 pressure differential with the filter in a clean and in a dirty condition;

13 (3) Elevation of pump suction and discharge in relation to the [pool or spa] *aquatic venue* water  
 14 surface level *or the surge tank*; and

15 (4) Determination of the total dynamic head of the circulation system for use in pump selection.

16 D. Surface to Bottom Flow Ratio *and Water Circulation*.

17 (1) An owner of a recreational pool, semipublic pool, or public spa *constructed with both surface*  
 18 *and bottom outlets* shall ensure that:

19 (a) Piping for surface outlets is designed to accommodate 80 percent of the flow; and

20 (b) Piping for bottom outlets is designed to accommodate 20 percent of the flow.

21 (2) An owner of a recreational pool or semipublic pool may have a gutter surface overflow  
 22 system with a flow design of 50 percent from the surface outlets and 50 percent from the bottom  
 23 outlets.

24 (3) *An owner of a public spray ground shall ensure that piping for outlets is designed to*  
 25 *accommodate 100 percent of the flow.*

## Draft Regulations for COMAR 10.17.01 – Aquatic Facilities and Venues

1 (4) *An owner of a recreational pool, semipublic pool or spa may construct the pool or spa with*  
2 *only surface outlets provided:*

3 (a) *Where the width of the pool or spa exceeds 30 feet, return inlets are not installed solely on*  
4 *the wall; and*

5 (b) *The circulation system is capable of meeting the required minimum turnover rate in §B of*  
6 *this regulation.*

7 E. Filter Capacity. An owner of [a recreational pool, semipublic pool, or public spa] *an aquatic*  
8 *venue shall ensure that a filter:*

9 (1) Operates within the filter design flow rate; *and*

10 (2) Has a filtration capacity sufficient to operate in the range between the minimum turnover rate  
11 and the filter design flow rate when the circulation system is at the:

12 (a) Lowest level of calculated total dynamic head when the filter is in a clean condition; and

13 (b) Highest level of calculated total dynamic head when the filter pressure differential is at the  
14 maximum allowed in Regulation .43E of this chapter.

15 F. Interconnections Between [Pools] *Aquatic Venues*. An owner of [a recreational pool,  
16 semipublic pool, or public spa] *an aquatic venue* shall ensure that a pool is not interconnected  
17 with a:

18 (1) Spa or wading pool except during the filling of a spa or wading pool; [and] *or*

19 (2) Spray [pool] *ground*.

### Summary of changes:

#### MAHC:

#### Relevant comments:

- 2015-105
- 2017-028
- 2017-101
- 2017-223
- 2017-224
- 2017-225

20 **.26 Circulation System Components.**

## Draft Regulations for COMAR 10.17.01 – Aquatic Facilities and Venues

- 1 A. Except as provided in §§B and H(1) of this regulation, an owner of [a recreational pool,  
2 semipublic pool, or public spa] *an aquatic venue* shall ensure that circulation system  
3 components, including skimmers, pumps, filters, multiport valves, adjustable output rate  
4 chemical feeders, flow-through chemical feeders, chemical process equipment, chlorine  
5 generators, ion generators, and other [pool and spa] *aquatic venue* equipment comply with  
6 Circulation System Components and Related Materials for Pools, Spas/Hot Tubs.
- 7 B. The Secretary shall accept [swimming pool, spa, or hot tub] *aquatic venue* circulation system  
8 components as meeting the requirements set forth in §A of this regulation if these items are in  
9 the current published NSF listing of swimming pool, spa, or hot tub circulation system  
10 components or a listing from organizations accredited by the American National Standards  
11 Institute (ANSI) for the certification of circulation system components.
- 12 C. Chemical Feeder and Process Equipment. An owner of [a recreational pool, semipublic pool,  
13 or public spa] *an aquatic venue* shall ensure that the capacity of chemical feeder and process  
14 equipment is adequate to:
- 15 (1) Provide the minimum required disinfectant residual to the [pool or spa] *aquatic venue* water,  
16 as required [in] *by* Regulation .44A of this chapter; and
- 17 (2) Establish breakpoint when the combined chlorine level is *at or over* [0.2] *0.4* ppm.
- 18 D. Chlorine Gas Feeders. An owner of [a recreational pool, semipublic pool, or public spa] *an*  
19 *aquatic venue* shall [ensure that the:
- 20 (1) Equipment installation, and operation of a chlorine gas feeder are in compliance with the  
21 American National Standard for Public Swimming Pools, with the exception that the word  
22 "shall" is substituted for the word "should", and the owner is required to comply with the  
23 specifications of Appendix E; and
- 24 (2) Recirculated water is treated downstream of the chlorine gas injection point to maintain the  
25 water's pH between 7.2 and 7.8. ] *not allow the use of chlorine gas feeders as a means of*  
26 *disinfecting an aquatic venue.*
- 27 E. Vacuum Systems.
- 28 (1) An owner shall ensure that a [recreational pool, semipublic pool, or] public *pool or spa* has a  
29 vacuum system for cleaning the pool or spa floor.
- 30 (2) An owner of a [recreational pool, semipublic pool, or] public *pool or spa* may use skimmer  
31 outlet pipes for vacuum purposes for *a* circulation [systems] *system* with four or fewer skimmers.
- 32 (3) For *a* circulation [systems] *system* with more than four skimmers or a gutter system, an  
33 owner of a [recreational pool, semipublic pool, or] public *pool or spa* shall ensure that a vacuum  
34 system is provided that is separate from the skimmer or gutter system.

## Draft Regulations for COMAR 10.17.01 – Aquatic Facilities and Venues

1 (4) If a vacuum [fittings are] *fitting is* provided within a [recreational pool, semipublic pool, or]  
2 public *pool or spa*, the owner shall ensure that the [fittings are] *fitting is*:

3 (a) Located at a convenient [locations] *location* approximately 1 foot below the water surface;  
4 and

5 (b) Provided with a flush removable [caps] *cap or a spring loaded safety cover either of which*  
6 *shall be in place at all times.*

7 (5) When the vacuum system is an integral part of the circulation system, an owner of a  
8 [recreational pool, semipublic pool, or] public *pool or spa* shall ensure that the vacuum line  
9 connection is before the pump hair and lint strainer.

10 F. Carbon Dioxide Feeders. An owner of [a recreational pool, semipublic pool, or public spa] *an*  
11 *aquatic venue* shall ensure that a carbon dioxide feeder system is:

12 (1) Installed and maintained in accordance with the manufacturer's specifications;

13 (2) Located in a [ventilated] *chemical storage area that meets the requirements provided in*  
14 *Regulation .29 of this chapter; [and]*

15 (3) Secured to prevent damage to the gas cylinder if the cylinder is subject to tipping[.]; *and*

16 (4) *Where carbon dioxide cylinders are located indoors, a monitor and alarm is provided to alert*  
17 *patrons and operators of carbon dioxide levels at or exceeding 1000 ppm or an oxygen*  
18 *concentration at or below 19.5 percent.*

19 G. Ozone Systems. An owner of [a recreational pool, semipublic pool, or public spa] *an aquatic*  
20 *venue* shall ensure that:

21 (1) *Chemicals, solvents, or combustible materials, other than those required for the operation of*  
22 *the recirculation and ozone generating equipment, are not stored in a room where ozone is used;*

23 (2) *Rooms which are designed to include ozone equipment are equipped with an emergency*  
24 *ventilation system capable of six air changes per hour;*

25 (3) *The exhaust intake is located 6 inches from the floor, on the opposite side of the room from*  
26 *the make-up air intake;*

27 (4) *The emergency ventilation system is arranged to run on command of an ozone-leak alarm or*  
28 *on command of a manual switch;*

29 (5) *The manual emergency ventilation switch is located outside the room and near the door to*  
30 *the room containing the ozone generation equipment;*

## Draft Regulations for COMAR 10.17.01 – Aquatic Facilities and Venues

- 1 (6) *Ozone rooms which are below grade are equipped with forced-draft ventilation capable of*  
2 *six air changes per hour;*
- 3 (7) *The ventilation system is arranged to run:*
- 4 (a) *Automatically concurrent with the ozone equipment and for at least a time allowing for 15 air*  
5 *changes after the ozone equipment is stopped;*
- 6 (b) *Upon activation of the ozone detection and alarm system; and*
- 7 (c) *On command of a manual switch;*
- 8 (8) *A room containing ozone generation equipment is equipped with an audible and visible ozone*  
9 *detection and alarm system;*
- 10 (9) *The alarm system consists of both an audible alarm capable of producing at least 85 decibels*  
11 *at ten feet distance, and a visible alarm consisting of a flashing light mounted in plain view of*  
12 *the entrance to the room containing the ozone generation equipment;*
- 13 (10) *The ozone sensor is located at a height between 18 and 24 inches above floor level and is*  
14 *capable of measuring ozone in the range of 0 to 2 ppm;*
- 15 (11) *The alarm system will alarm when the ozone concentration equals or exceeds 0.1 ppm in the*  
16 *room;*
- 17 (12) *The activation of the alarm system will shut off the ozone generating equipment and turn on*  
18 *the emergency ventilation system;*
- 19 [(1)] (13) *An ultraviolet light ozone system is used and installed according to Circulation System*  
20 *Components and Related Materials for Pools, Spas/Hot Tubs;*
- 21 [(2)] (14) *A corona discharge ozone system is used and installed according to Circulation System*  
22 *Components and Related Materials for Pools, Spas/Hot Tubs (NSF/ANSI-50 2013), and the*  
23 *following requirements:*
- 24 (a) *The system is designed to provide a minimum concentration of ozone generated to be 1.5*  
25 *percent by weight;*
- 26 (b) *The ozone gas is diffused through a static mixer into a contact column with a sidestream flow*  
27 *of recirculated water equal to a minimum of 5 percent of the required turnover rate;*
- 28 (c) *The system is designed to provide a contact time of:*
- 29 (i) [2] *Two minutes when used in conjunction with a chlorine disinfectant; or*
- 30 (ii) [1] *One minute when used in conjunction with a bromine disinfectant;*

## Draft Regulations for COMAR 10.17.01 – Aquatic Facilities and Venues

- 1 (d) The system provides a minimum contact time value of 0.5 milligram/liter in the contact  
2 column when the contact time value equals the concentration of dissolved ozone in  
3 milligrams/liter times the contact time in minutes;
- 4 (e) The air feed, which is natural or oxygen enriched air, is filtered to remove particulates and  
5 dehumidified to a minimum dew point of minus 60°C before the ozone generating chamber;
- 6 (f) An ozone gas feed line is ozone resistant;
- 7 (g) Valves are provided to control flow through the system;
- 8 (h) Offgas venting from the contact column is:
- 9 (i) Equipped with an ozone destruct system that removes all ozone before release to the  
10 atmosphere; or
- 11 (ii) Returned to the main recirculation line when used in conjunction with a bromine disinfectant;
- 12 (i) When necessary, a foam suppression system is provided before offgas venting;
- 13 (j) The oxidation reduction potential of the sidestream after contact and before dissolved ozone  
14 removal is a minimum of 650 millivolts;
- 15 (k) The dissolved ozone is removed from the sidestream using granulated activated carbon  
16 before remixing with the recirculated water when used in conjunction with a chlorine  
17 disinfectant;
- 18 (l) The ozone generating system shuts off if the water recirculating system shuts off or if the  
19 vacuum is lost on the ozone gas output line;
- 20 (m) The ozone gas output is under negative pressure or a vacuum; *and*
- 21 (n) [The ozone generation area is ventilated at 2 cfm per square foot of floor area to prevent the  
22 build up of excess ozone; and
- 23 (o)] The recirculated water is treated to maintain the pH between 7.2 and 7.8.
- 24 H. [An owner of a recreational pool, semipublic pool, or public spa may connect an equalization  
25 line for a skimmer to the main drain line in a wading pool, or other pool that does not have  
26 sufficient water depth, for the installation of the equalizer line through the pool wall below the  
27 skimmer throat.] *Skimmers.*
- 28 (1) *The Secretary shall accept skimmers on a recreational pool, semipublic pool, or public spa*  
29 *as meeting the requirements set forth in §A of this regulation and not require the installation of*  
30 *equalizer lines or equalizer line covers if:*



Draft Regulations for COMAR 10.17.01 – Aquatic Facilities and Venues

1 (a) *The skimmer is connected to another skimmer or main drain line that cannot be isolated by a*  
2 *valve or other means;*

3 (b) *The skimmer is provided with a vented lid;*

4 (c) *Except for an equalizer line, the skimmer is in compliance with Circulation System*  
5 *Components and Related Materials for Pools, Spas/Hot Tubs;*

6 (d) *The flow rate through the skimmer is not less than 14 or greater than*  
7 *35gpm; and*

8 (e) *The skimmer is provided with a means for adjusting the flow rate; and*

9 (2) *The owner shall ensure that:*

10 (a) *One skimmer is provided per:*

11 (i) *50 feet of aquatic venue perimeter; or*

12 (ii) *500 square feet of aquatic venue water surface area or fraction thereof, whichever is greater;*

13 (b) *A minimum of two skimmers are installed; and*

14 (c) *The skimmers are spaced to provide maximum skimming action of the water surface.*

15 I. *An owner shall ensure that all chemical feeders that operate independently of the circulation*  
16 *pump are provided with an automatic means to be disabled through an electrical interlock with*  
17 *at least one of the following:*

18 (1) *Recirculation pump power;*

19 (2) *Flow meter, flow switch, or pressure switch in the return line; or*

## Draft Regulations for COMAR 10.17.01 – Aquatic Facilities and Venues

- 1 (3) *Chemical control power and paddle wheel or flow cell on the chemical controller if safety*
- 2 *test confirms feed systems are disabled through the controller when the pump is turned off, loses*
- 3 *prime, or filters are backwashed.*

### Summary of changes:

#### MAHC:

#### Relevant comments:

- 2015-008
- 2015-037
- 2015-057
- 2017-029
- 2017-102
- 2017-103
- 2017-104
- 2017-105
- 2017-144
- 2017-226
- 2017-227
- 2017-228
- 2017-229

### 4 **.27 Diving Area and Equipment.**

5 An owner of a public pool shall ensure that:

6 A. [A pool used for accredited competitive aquatic events as defined in §3 of the American  
7 National Standard for Public Swimming Pools is in compliance with §6.4.1 of American  
8 National Standard for Public Swimming Pools;

9 B.] The dimensions of [a pool] *an aquatic venue* diving area are in conformance with [the  
10 following minimum dimensions and explanatory diagram:

11 (1) Minimum dimensions:

#### *Diving Board Height (H) Above Water*

<i>Dimension</i>	<i>Deck Level Board (20" or less)</i>	<i>One Meter Diving Board (More than 20" but not more than 39")</i>	<i>Three Meter Diving Board (More than 3'3", but not more than 10'0")</i>

Draft Regulations for COMAR 10.17.01 – Aquatic Facilities and Venues

	<i>Minimum</i>	<i>Preferred</i>	<i>Maximum</i>	<i>Minimum</i>	<i>Preferred</i>	<i>Maximum</i>	<i>Minimum</i>	<i>Preferred</i>
D <sub>0</sub>	6'0"	—	—	6'0"	—	—	6'0"	—
D <sub>1</sub>	9'0"	10'0"	—	10'0"	12'0"	—	12'6"	13'0"
D <sub>2</sub>	2'9"	3'0"	3'6"	3'0"	3'0"	—	3'0"	3'0"
O <sub>h</sub>	2'6"	3'0"	3'0"	4'10 1/2"	6'0"	—	4'10 1/2"	6'0"
L <sub>1</sub>	15'0"	16'0"	—	18'0"	20'0"	—	20'0"	20'0"
L <sub>2</sub>	12'0"	15'0"	—	15'0"	21'0"	—	22'6"	24'0"
L <sub>3</sub>	15'0"	24'0"	—	15'0"	24'0"	—	24'0"	24'0"
S <sub>1</sub>	—	1:2	1:10	—	1:12	1:12	1:12	1:12
S <sub>2</sub>	—	—	1:3	—	—	1:3	1:3	1:3
B <sub>1</sub>	6'0"	6'0"	9'0"	9'0"	16'0"	—	—	16'0"

1 Where:

2 D<sub>0</sub> = Water depth at cove radius;

3 D<sub>1</sub> = Water depth below board plummet line maintained for entire length of L<sub>1</sub> allowing for slope  
4 to the drain;

5 D<sub>2</sub> = Water depth at shallow end of pool;

6 O<sub>h</sub> = Length of board overhang above pool;

7 L<sub>1</sub> = Length from below board plummet line to start of transition slope;

8 L<sub>2</sub> = Length of transition zone;

9 L<sub>3</sub> = Length of shallow end of pool;

10 S<sub>1</sub> = Shallow end slope ratio;

11 S<sub>2</sub> = Transition slope ratio; and

12 B<sub>1</sub> = Board length.

13 (2) Explanatory diagram

(2) Explanatory diagram:

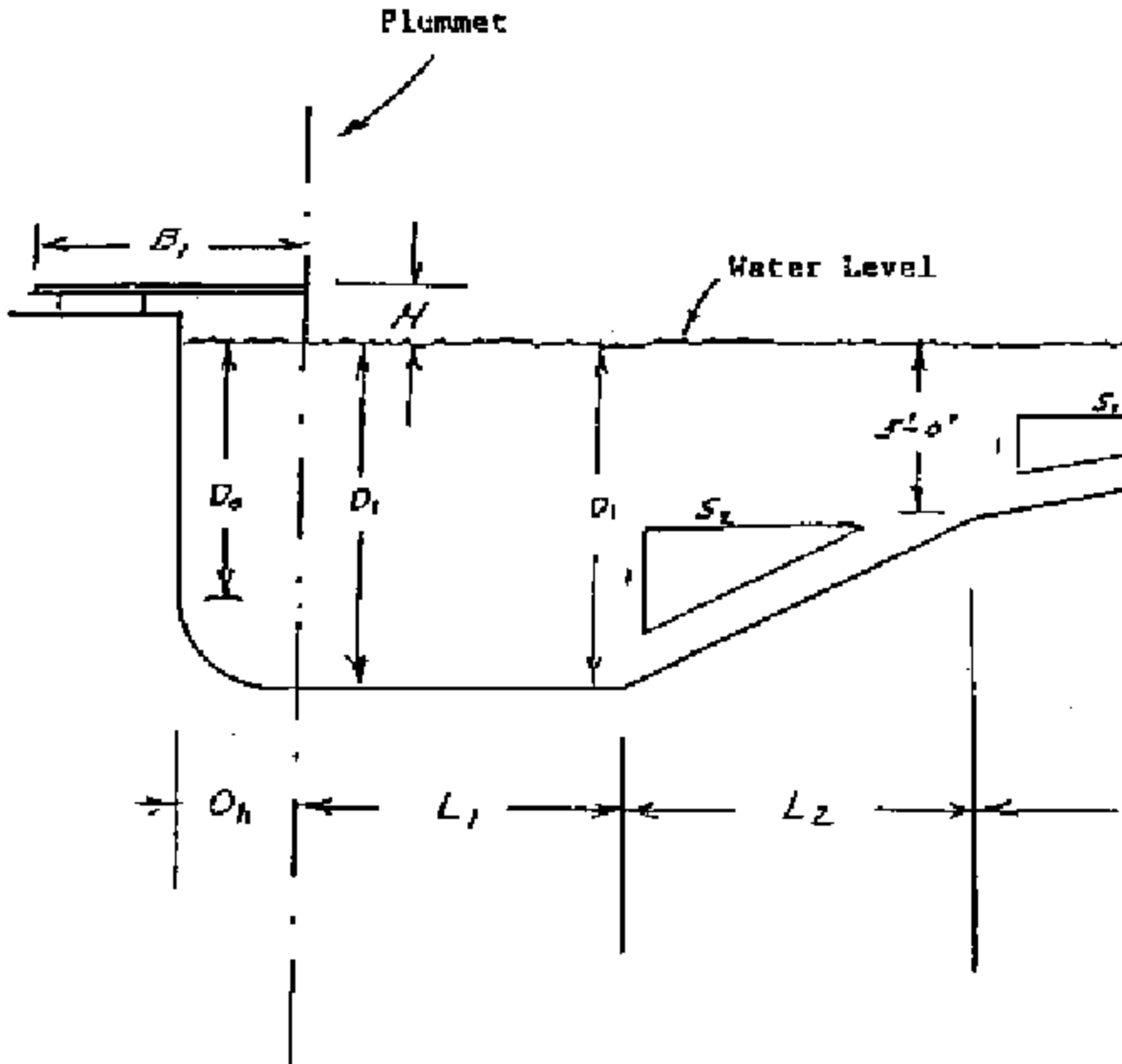

1

2 (3) The transitional radius from wall to floor are in conformance with Article IV of the American  
3 National Standard for Public Swimming Pools.] §§6.5—6.6.2 of the American National Standard  
4 for Public Swimming Pools;

## Draft Regulations for COMAR 10.17.01 – Aquatic Facilities and Venues

1 [C.] B. Diving equipment is installed in compliance with [§§7.2.5—7.2.5.6] §§7.2.5—7.2.5.7 of  
2 the American National Standards for Public Swimming Pools;

3 [D.] C. Unobstructed clearance is provided for a diving board in conformance with the following  
4 minimum dimensions:

5 (1) A minimum height [of:

6 (a) 13 feet measured upward from the plummet of a diving board; or

7 (b) Greater than 13 feet if specified by the manufacturer of the diving board] *in conformance*  
8 *with §7.2.3 of the American National Standard for Public Swimming Pools;*

9 (2) A clearance as required [in §D(1)] *by §C(1)* of this regulation extending:

10 (a) 16 feet forward of the plummet;

11 (b) 8 feet behind the plummet; and

12 (c) 8 feet to both sides of the plummet;

13 (3) A minimum distance of 10 feet between the plummets of adjacent diving boards; and

14 (4) A minimum distance between a diving board plummet and a side wall of:

15 (a) 10 feet for a diving board [20 inches] *one meter* or less above the water line; and

16 (b) 12 feet for a diving board greater than [20 inches] *one meter* above the water line;

17 [E.] D. Diving boards in excess of 10 feet above the water line and diving platforms are in  
18 compliance with §7.2.4 of the American National Standard for Public Swimming Pools; and

19 [F.] E. A starting block:

20 (1) Is located on the pool deck so that a swimmer dives into a minimum of 5 feet water depth; or

21 (2) At a pool constructed before February 10, 1997, is located so that a swimmer dives into a  
22 minimum of:

23 (a) 5 feet water depth when the starting block is used without supervision; or

24 (b) 4 feet water depth when the starting block is:

25 (i) Used in a controlled environment such as a swimming competition under the supervision of  
26 an instructor; and

Draft Regulations for COMAR 10.17.01 – Aquatic Facilities and Venues

- 1 (ii) Restricted from unsupervised use or is removed when not under supervised use.

**Summary of changes:**

**MAHC:**

**Relevant comments:**

- 2017-030

2 **.28 [Suction] Entrapment Prevention.**

3 To prevent [a suction] *an* entrapment hazard, an owner shall ensure that:

4 A. [A vacuum fitting is capped when not in use;

5 B] A vacuum line *is equipped with an independent valve and the valve is in the closed position*  
6 *when not in use;*

7 [C] *B. Except as provided in [§§F and G] §E of this regulation, the main drain for a [public]:*

8 *(1) Public pool or spa complies with 15 U.S.C. §8003 and is:*

9 [(1)] *(a) Connected to a minimum of two main drain outlets that are:*

10 [(a)] *(i) Not isolated by a valve or other means;*

11 [(b)] *(ii) Spaced at least 3 feet [from edge to edge] apart measured from center to center of sump*  
12 *or located on two different planes; and*

13 [(c)] *(iii) Hydraulically balanced; or*

14 [(2)] *(b) An unblockable drain[.]; and*

15 *(2) Within the splash zone of a public spray ground complies with 15 U.S.C. §8003;*

16 [D] *C. A drain is covered with a securely attached drain cover in compliance with the:*

17 [(2)] *(1) American National Standard for Public Swimming Pools; and*

18 *(2) 15 U.S.C. §8003[.];*

19 [E] *D. A skimmer [is:*

## Draft Regulations for COMAR 10.17.01 – Aquatic Facilities and Venues

1 (1) Connected to an equalization line, main drain line, vent, or another skimmer that cannot be  
2 isolated by a valve or other means, or

3 (2) Provided with a vented lid;] *complies with Regulation .26A of this chapter;*

4 [F] *E. A public pool or spa constructed before February 10, 1997 is provided [by June 1, 2002,]*  
5 *with:*

6 (1) At least two hydraulically balanced drain outlets [spaced a minimum of 3 feet from edge to  
7 edge that cannot be isolated to create a single outlet for each circulation pump, as illustrated in  
8 Regulation .28-1A of this chapter] *in compliance with §B(1) of this regulation;*

9 (2) [A channel] *An unblockable drain system that [is at least 3 feet from edge to edge, as*  
10 *illustrated in Regulation .28-1B of this chapter] complies with §B(1) of this regulation; or*

11 (3) An approved safety vacuum release system[.]; *and*

12 [G. As an interim measure, until a pool or spa constructed before February 10, 1997 is in  
13 compliance with §F of this regulation:

14 (1) A pool or spa has a minimum of two outlets that cannot be isolated to create a single outlet  
15 per pump; and

16 (2) These outlets are provided by connecting the main drain line to a skimmer line so that the  
17 lines cannot be isolated to create a single outlet, as illustrated in Regulation .28-1C of this  
18 chapter, assuring that:

19 (a) The skimmer line does not become blocked within the skimmer housing at any time;

20 (b) Associated valves are locked in an open position to prevent the drain or the skimmer from  
21 becoming a single source of suction; and

22 (c) Associated valves are permanently tagged with a warning to maintain the valves in the open  
23 position at all times when the pool or spa is in use;

24 H. A pool or spa is in compliance with the following:] *F. An owner shall ensure that:*

25 (1) A *submerged* suction outlet is provided with a cover that complies with the American  
26 National Standard for Public Swimming Pools;

27 (2) A *submerged* suction [fitting] *outlet* complies with 15 U.S.C. §8003;

28 (3) [Suction] *A submerged suction outlet [covers are] cover is* in good condition, with no breaks,  
29 cracks, or other defects that could affect the structural integrity of the cover;

## Draft Regulations for COMAR 10.17.01 – Aquatic Facilities and Venues

- 1 (4) [Suction] *A suction outlet [covers are] cover is secured according to manufacturers' directions*  
2 *and in such a way that the [covers] cover cannot be removed without the use of [tools] a tool;*
- 3 (5) [A pool or spa that does not have] *When an aquatic venue has a submerged suction [outlets]*  
4 *outlet that is not in compliance with this regulation [has], all pumps are immediately shut off*  
5 *and the aquatic venue is closed until [the pool or spa has been] brought into compliance with this*  
6 *regulation;*
- 7 (6) *The maximum velocity in the design of the drain piping does not exceed 6 feet per second*  
8 *when 100 percent of the circulation system design flow is drawn through the drain piping of any*  
9 *single drain;*
- 10 (7) [A pool or spa facility has a comprehensive written maintenance program that addresses the  
11 following:
- 12 (a) *If a suction outlet cover is cracked or broken, the pump shall be immediately shut off and the*  
13 *cover shall be replaced;*
- 14 (b) *Covers shall be anchored in accordance with the manufacturer's specifications and supplied*  
15 *parts, and only manufacturer specified, noncorrosive fasteners may be used;*
- 16 (c) *Lines and equipment shall be labeled or color coded for ready identification; and*
- 17 (d) *The on/off switch for circulation pumps shall be clearly identified and labeled; and] A*  
18 *comprehensive written maintenance program is prepared and implemented that includes*  
19 *procedures for the operator to:*
- 20 (a) *Keep the written maintenance program on file with the operating records at the aquatic*  
21 *venue;*
- 22 (b) *Make the written maintenance program available to the Department for inspection;*
- 23 (c) *Shut off the pump and close the aquatic venue should the operator discover a suction outlet*  
24 *cover that is cracked, broken or otherwise not in compliance with §F(3) of this regulation;*
- 25 (d) *Replace a suction outlet cover that is cracked, broken or otherwise not in compliance with*  
26 *§F(3) of this regulation;*
- 27 (e) *Close the aquatic venue if the circulation pump is off for longer than 15 minutes; and*
- 28 (f) *Not allow the use of the aquatic venue until the circulation pump is operating if the*  
29 *circulation pump is found to be off before opening the aquatic venue; and*
- 30 (8) [Check valves] *A check valve in the suction line to [pumps are] a pump is removed to allow*  
31 *backflow of water or air to release the suction when the pump is shut off or when an influent*  
32 *blockage detection device is activated.]; and*



## Draft Regulations for COMAR 10.17.01 – Aquatic Facilities and Venues

1 I. A pool and spa operator completes the Pool and Spa Entrapment Hazards Checklist provided  
2 by the Secretary, or an equivalent form, on a daily basis before the pool or spa is open for that  
3 day's use.]

4 [.28-1 Drain System Figures.

5 A. Dual Drain System.

### **.28-1 Drain System Figures.**

#### **A. Dual Drain System.**

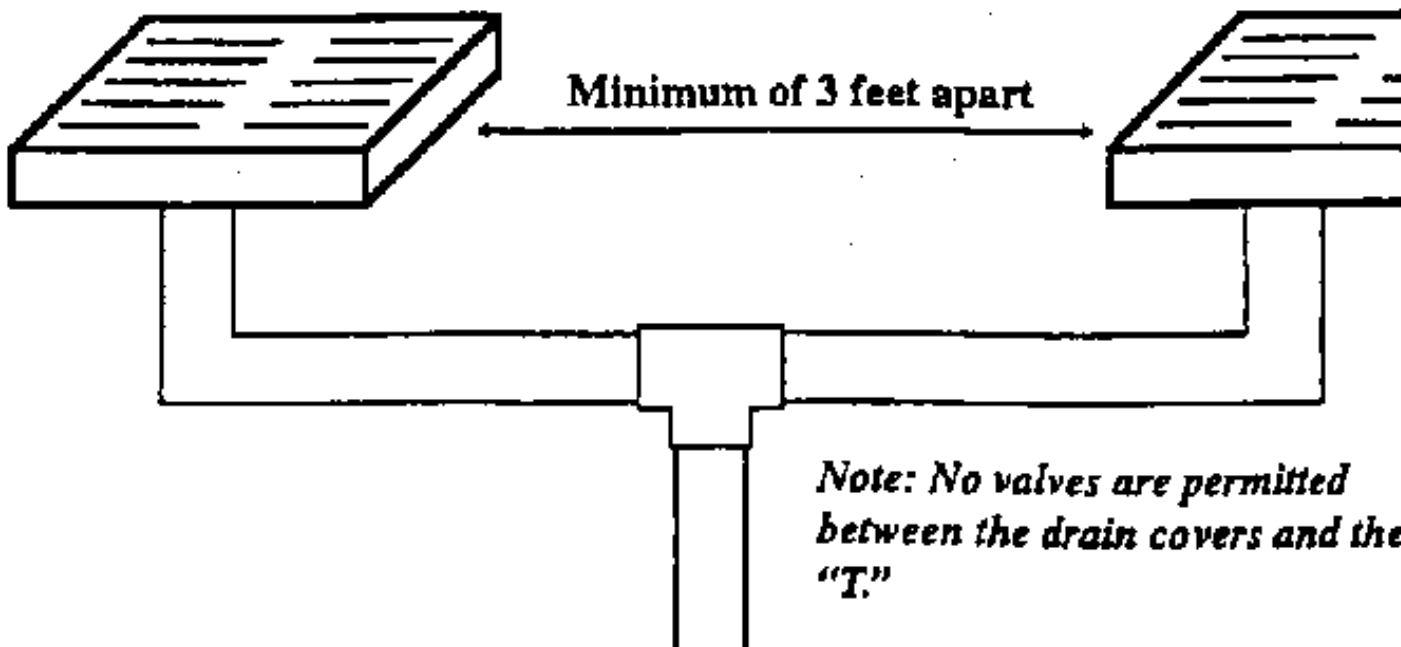

6

7 B. Channel Drain System.

### B. Channel Drain System.

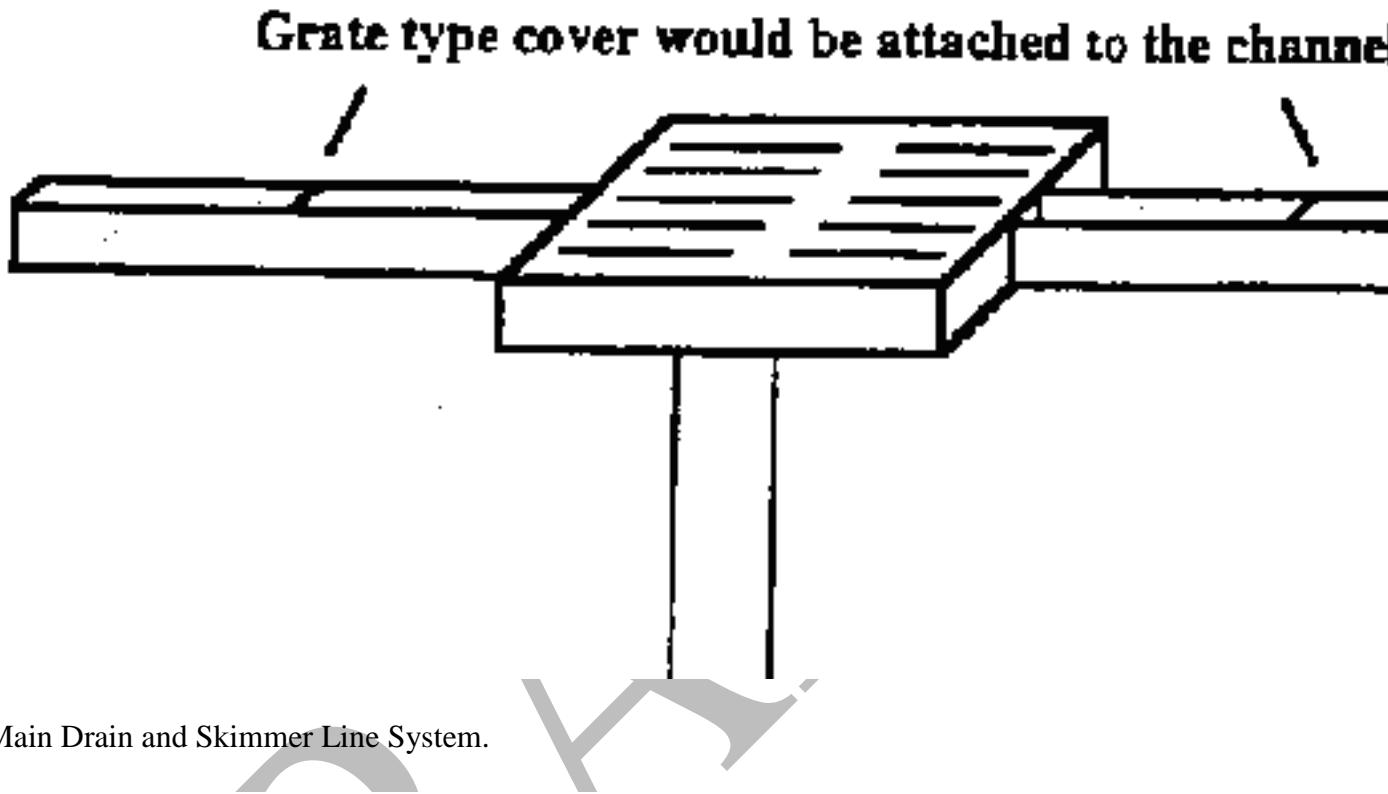

### C. Main Drain and Skimmer Line System.



1

**Summary of changes:**

**MAHC:**

**Relevant comments:**

- 2015-011
- 2017-106
- 2017-107
- 2017-145
- 2017-146
- 2017-230
- 2017-231

2 **].29 Chemical Storage Area.**

3 An owner shall ensure that [a recreational pool, semipublic pool, or public spa] *an aquatic venue*  
4 has a chemical storage area that:

5 A. Is protected against the weather, excess heat, and moisture; and

6 B. Has:

7 (1) [A lockable door which can be opened from the inside,] *An entrance door that:*

8 *(a) Allows complete and unencumbered access to the chemical storage area;*

9 *(b) Is equipped with:*

10 *(i) An automatic closer;*

11 *(ii) An automatic lock; and*

12 *(iii) A lock that requires a key or combination to open from the outside;*

13 *(c) Is installed and maintained to ensure that the door closes completely and latches without*  
14 *human assistance; and*

15 *(d) Is designed and installed to be opened by one hand from the inside of the room under all*  
16 *circumstances, without the use of a key or tool;*

17 (2) [Ventilation] *Continuous mechanical exhaust ventilation with the exhaust vent intake placed*  
18 *at a height less than or equal to 3 feet from the floor of the chemical storage area, discharged to*

## Draft Regulations for COMAR 10.17.01 – Aquatic Facilities and Venues

- 1 *limit exposure to the public* that is sized at 2 cfm per square foot of floor area and that exhausts  
2 to the open air[,];
- 3 (3) A minimum of 20 [footcandles] 20 lumens of illumination[,] *per square foot of floor space*  
4 *within the chemical storage area;* and
- 5 (4) Storage for chemicals in accordance with the [material] safety data sheet for a particular  
6 chemical.

### Summary of changes:

#### MAHC:

#### Relevant comments:

- 2015-012
- 2015-022
- 2015-023
- 2015-038
- 2015-044
- 2015-082
- 2015-083
- 2015-106
- 2017-031
- 2017-108
- 2017-232
- 2017-233
- 2017-234

### 7 **.30 Hydrostatic Relief Valves.**

- 8 An owner shall ensure that an in-ground recreational pool, semipublic pool, or public spa has  
9 hydrostatic relief valves as needed to relieve the hydrostatic pressure from ground water when  
10 the pool or spa is empty.

### Summary of changes:

#### MAHC:

#### Relevant comments:

- 2015-058
- 2017-032

1 **.31 Filter Backwash Water and Deck Drainage Disposal.**

2 A. An owner shall ensure that:

3 (1) The disposal of filter backwash water and [pool or spa] *aquatic facility and venue* wastewater  
4 conforms with:

5 (a) COMAR 09.20.01[.];

6 (b) Local sanitary code requirements[.]; and

7 (c) Discharge requirements of COMAR [26.08.01 ----- 26.08.04] *26.08.01—26.08.04*; and

8 (2) Deck drainage disposal conforms with:

9 (a) COMAR 09.20.01[.]; and

10 (b) Local plumbing code requirements.

11 B. An owner may not return filter backwash water or other wastewater to [a pool or spa,] *an*  
12 *aquatic venue* except for filter backwash water that has been filtered to remove particulates and  
13 treated to eliminate coliform bacteria and waterborne pathogens.

**Summary of changes:**

**MAHC:**

**Relevant comments:**

- 2017-033

14 **.32 Illumination of Water, Deck, and Walkway.**

15 An owner shall ensure that an indoor [recreational pool, semipublic pool, or public spa,] *aquatic*  
16 *venue* or one used [during nighttime] *before sunrise or after sunset*, is provided with:

17 A. Even illumination of the water, deck, and walkways;

18 B. Illumination of the water and deck *of an aquatic venue* that is:

19 (1) A combination of underwater lighting and deck lighting so that the:

20 (a) Underwater lighting [yields] *provides* at least [0.5 watt] *8 lumens* per square foot of water  
21 surface area[.]; and

## Draft Regulations for COMAR 10.17.01 – Aquatic Facilities and Venues

- 1 (b) [Deck lighting yields] *Lighting for the required deck area provides at least [0.6 watt] 10*  
2 *lumens per square foot of required deck area [or at least 15 footcandles]; or*
- 3 (2) [Overhead lighting yielding] *Lighting for the required deck area provides at least [2 watts]*  
4 *20 lumens per square foot of required deck area [or at least 20 footcandles of light] that is*  
5 *directed onto the deck and the water surface so that the bottom of the entire [pool or spa bottom]*  
6 *aquatic venue is clearly visible;*
- 7 C. Lighting that minimizes reflection from the water surface [so that the visibility of the pool or  
8 spa bottom is not obscured; and] *so that the entire bottom of an aquatic facility is clearly visible;*
- 9 D. Walkway lighting yielding at least [15 footcandles of light.] *10 lumens per square foot of the*  
10 *walkway; and*
- 11 E. *Illumination of the splash zone and deck that provides at least 10 lumens per square foot of*  
12 *the splash zone and deck.*

### Summary of changes:

#### MAHC:

#### Relevant comments:

- 2017-034
- 2017-109
- 2017-235

### 13 **.33 Ventilation of an Indoor [Recreational Pool, Semipublic Pool, or Public Spa] Aquatic** 14 **Venue.**

15 An owner shall ensure that an indoor [recreational pool, semipublic pool, or public spa] *aquatic*  
16 *venue* has:

17 A. A [ventilating] *ventilation* system capable of:

18 (1) Exhausting 1 1/2 cfm of air per square foot of enclosed area[, or]; *and*

19 (2) Dehumidifying the recirculated air from the enclosed area; [and]

20 B. Make-up air equal to the volume of exhausted air or as required [in] *by the ventilation system*  
21 *specifications[.], has a ventilation system equipped with;*

22 C. *An exhaust vent placed at a height less than or equal to 3 feet from the floor of the*  
23 *natatorium; and*

## Draft Regulations for COMAR 10.17.01 – Aquatic Facilities and Venues

- 1 *D. A make-up air vent place on the opposite side of the natatorium from the exhaust vent.*

### Summary of changes:

#### MAHC:

#### Relevant comments:

- 2015-059
- 2015-084
- 2017-035
- 2017-064
- 2017-110
- 2017-236

### 2 **.34 Plumbing.**

3 A. Water Supply System. An owner shall ensure that a water supply system at [a public pool or  
4 spa] *an aquatic venue* is in conformance with:

5 (1) COMAR 26.04.01[, 26.04.03, and 26.04.04;

6 (2) COMAR 09.20.01; and

7 (3)] (2) *COMAR 26.04.03*;

8 (3) *COMAR 26.04.04*;

9 (4) *COMAR 09.20.01*; and

10 (5) Local plumbing code requirements.

11 B. Sewage Disposal System. An owner shall ensure that a sewage disposal system at [a public  
12 pool or spa] *an aquatic venue* is in conformance with:

13 (1) COMAR 26.04.02 [and 26.04.03];

14 (2) *COMAR 26.04.03*;

15 (3) COMAR 09.20.01; and

16 [(3)](4) Local plumbing code requirements.

## Draft Regulations for COMAR 10.17.01 – Aquatic Facilities and Venues

1 C. Drinking Fountains. An owner shall ensure that [a recreational pool, semipublic pool, or  
2 public spa enclosure] *an aquatic venue* has at least one drinking fountain *within 100 feet of the*  
3 *entrance gate to an aquatic venue* for every 5,000 square feet of water surface *or splash zone*  
4 *area*.

5 D. Hose Bibbs. An owner of [a recreational pool, semipublic pool, or public spa] *an aquatic*  
6 *venue* shall ensure that the following locations have an accessible hose bibb equipped with an  
7 atmospheric vacuum breaker:

8 (1) On the deck at 150 feet intervals;

9 (2) In an equipment room *or that is accessible within 50 feet of the equipment room so that a*  
10 *hose can service the entire equipment room*; and

11 (3) In both a men's and a women's bathhouse.

12 E. Fill Spouts *and Automatic Water Level Controllers*.

13 (1) If a fill spout is installed at a public pool or spa, the owner shall ensure that the fill spout is:

14 [(1)](a) Installed within 10 inches of a ladder or handrail or in front of a lifeguard stand whose  
15 supports are immediately adjacent to the pool or spa [rim] *coping*, so that the fill spout does not  
16 present a tripping hazard or a puncture hazard;

17 [(2)](b) Not installed over a seat bench;

18 [(3)](c) Braced or constructed so the fill spout does not flex downward; [and]

19 [(4)](d) Provided with a flexible cover on the tip of the fill spout [if the spout presents a potential  
20 for injury to an individual using a pool or spa.]; *and*

21 (e) *Installed with an air gap that:*

22 (i) *Is two times the diameter of the fill spout; and*

23 (ii) *Separates the fill spout from the maximum water level of the pool or spa; and*

24 (2) *If an automatic water level controller or inline manual fill is installed at a public pool, spa or*  
25 *spray ground, the owner shall ensure that an air gap or other approved backflow prevention*  
26 *device is provided.*

27 F. Backflow Prevention. An owner of [a public pool or spa] *an aquatic facility* shall ensure that[:

28 (1) A pool or spa] *an aquatic facility* has backflow protection for:

29 [(a)] (1) A potable water supply, in conformance with COMAR 09.20.01[.]; and



## Draft Regulations for COMAR 10.17.01 – Aquatic Facilities and Venues

- 1 [(b)] (2) Wastewater, in conformance with COMAR 09.20.01[]; and
- 2 (2) An air gap that is two times the diameter of the fill spout separates the fill spout from the  
3 flood rim level of the pool or spa].
- 4 G. Source of Water. An owner of [a public pool or spa] *an aquatic venue* shall ensure that:
- 5 (1) When [a public pool or spa] *an aquatic venue* is filled with water from a [nonpotable] *non-*  
6 *potable* source, such as a water tank holding [nonpotable] *non-potable* water or surface water[,  
7 the]:
- 8 (a) [Water] *The water* is filtered, treated, and disinfected after addition to the [pool or spa]  
9 *aquatic venue* to meet the requirements of Regulation .44 of this chapter[,]; and
- 10 (b) [Pool or spa] *An aquatic venue* is not used until a bacteriological sample taken by the  
11 Secretary indicates that there are no coliform organisms in the water; and
- 12 (2) [Public pool or spa] *Aquatic venue* make-up water:
- 13 (a) Is from a potable source[,]; and
- 14 (b) Having an iron level over 0.3 ppm is treated to lower the iron level to 0.3 ppm or less before  
15 the make-up water is added to [a pool or a spa] *an aquatic venue*.

### Summary of changes:

#### MAHC:

#### Relevant comments:

- 2015-024
- 2015-085
- 2017-036
- 2017-058
- 2017-111
- 2017-112

### 16 **.35 Toilet, Hand Sink, and Shower Facilities.**

- 17 A. Except as provided in §B of this regulation, an owner shall ensure that [a recreational pool,  
18 semipublic pool, or public spa] *an aquatic venue* has:
- 19 (1) A bathhouse, toilets, hand sinks, and showers within 100 feet of an entrance gate to the [pool  
20 or spa] *aquatic venue* [in accordance with the American National Standard for Public Swimming  
21 Pools, Articles 19.1—19.6.13];
- 22 (2) At least a minimum number of toilets, hand sinks, and showers based on:

## Draft Regulations for COMAR 10.17.01 – Aquatic Facilities and Venues

- 1 (a) The [maximum user load of the pool or spa] *theoretical peak occupancy* as set forth in  
2 Regulation .19B of this chapter;
- 3 (b) Fixture ratios [set forth in §A(1) of this regulation] *in accordance with the American*  
4 *National Standard for Public Swimming Pools, Articles 19.1—19.6.13*; and
- 5 (c) State and local building codes;
- 6 (3) 50 percent of the required fixtures designated for use by each sex, unless the [pool or spa]  
7 *aquatic venue* is for one sex only; and
- 8 (4) At least 50 percent of the required showers located within a bathhouse.
- 9 B. An owner is not required to provide [toilet, hand sink, and] shower facilities at [a recreational  
10 pool, semipublic pool, or public spa] *an aquatic venue* when bathers have access to equivalent  
11 facilities in:
- 12 (1) Living quarters not more than 500 feet from [a pool or a spa] *an aquatic venue* entrance; or
- 13 (2) A building or buildings not more than 500 feet from [a pool or a spa] *an aquatic venue*  
14 entrance.
- 15 C. An owner shall ensure that equivalent facilities used by [recreational pool, semipublic pool, or  
16 public spa] *aquatic venue* bathers and patrons of a recreational center, health club, marina, or  
17 other facility are in compliance with:
- 18 (1) Section A of this regulation; and
- 19 (2) State or local plumbing codes regarding fixtures and dressing area for the patrons sharing the  
20 equivalent facilities.

### Summary of changes:

#### MAHC:

#### Relevant comments:

- 2017-037
- 2017-113
- 2017-237

### 21 **.36 Antiscald Protection for Showers.**

22 An owner of [a recreational pool, semipublic pool, or public spa] *an aquatic venue* shall ensure  
23 that each shower has an approved pressure-balanced, [antiscald] *anti-scald* device that limits the  
24 delivered water temperature to below 115°F.

## Draft Regulations for COMAR 10.17.01 – Aquatic Facilities and Venues

### Summary of changes:

#### MAHC:

#### Relevant comments:

- 2017-238

### 1 **.37 Accommodations for Disabled Individuals.**

2 An owner shall ensure that [a public pool or spa] *an aquatic venue* is in compliance with all  
3 applicable federal, State, and local codes governing facilities for disabled individuals, including  
4 COMAR 05.02.02.

### Summary of changes:

#### MAHC:

#### Relevant comments:

- 2017-038
- 2017-239

### 5 **.38 Equipment Installation and Operating Instructions.**

6 An owner of [a public pool or spa] *an aquatic venue* shall ensure that:

7 A. [Pool and spa] *Aquatic venue* equipment is installed according to manufacturers' instructions  
8 and this chapter;

9 B. Valves, controls, gauges, filters, pumps, feeders, and other operating equipment are easily  
10 accessible;

11 C. Valves, controls, and piping are permanently numbered, labeled, or color-coded to identify  
12 their purpose or function; and

13 D. Operating instructions for the circulation and water treatment systems:

14 (1) Refer to the number, label, or color code of the valves, controls, and piping[.]; and

15 (2) Are posted in the equipment room in a water-resistant cover.

### Summary of changes:

#### MAHC:

#### Relevant comments:

- 2017-039

## Draft Regulations for COMAR 10.17.01 – Aquatic Facilities and Venues

### 1 **.39 Maintenance.**

2 An owner of [a public pool or spa] *an aquatic facility or venue* shall ensure that:

3 A. An inspection of [the pool or spa and related facilities] *an aquatic facility and venue* is made  
4 at least once a [week] *day* by the operator for the purpose of maintaining [the pool or spa] *an*  
5 *aquatic facility and venue* in compliance with this chapter;

6 B. [The pool or spa and its related facilities are] *An aquatic facility and venue* is maintained in a  
7 safe, clean, and orderly condition;

8 C. A broken, damaged, or malfunctioning [fixture] *component* is promptly repaired or replaced;  
9 and

10 D. [The pool or spa is] *An aquatic facility and venue* are left in a safe condition when closed for  
11 the season.

#### Summary of changes:

#### MAHC:

#### Relevant comments:

- 2017-040
- 2017-240

### 12 **.40 [Public Pool and Spa] Aquatic Facility and Venue Safety.**

13 A. First Aid and Lifesaving Equipment. An owner shall ensure that *a*:

14 (1) [A recreational] *Recreational* pool is provided with *a*:

15 (a) [A first aid kit as recommended by the American Red Cross] *Continuously stocked, adequate*  
16 *supply of first aid supplies to include, at a minimum:*

17 (i) *A First Aid Guide;*

18 (ii) *Absorbent compresses;*

19 (iii) *Adhesive bandages;*

20 (iv) *A roll of adhesive tape;*

21 (v) *Sterile pads;*

Draft Regulations for COMAR 10.17.01 – Aquatic Facilities and Venues

- 1 (vi) *Scissors*;
- 2 (vii) *A roll of elastic wrap*;
- 3 (viii) *An emergency blanket*;
- 4 [(b) A face mask for CPR] (ix) *A resuscitation mask with one-way valve*; and
- 5 [(c)] (x) Disposable medical grade examination gloves;
- 6 [(d) A bloodborne] (b) *Blood borne* pathogen control kit, to include, at a minimum:
- 7 (i) *Three antimicrobial towelettes*;
- 8 (ii) *One – seven to ten gallon biohazard bag with tie*;
- 9 (iii) *One bottle of alcohol gel*;
- 10 (iv) *One roll of body fluid clean-up kit paper*;
- 11 (v) *One pair of nitrile ANSI gloves*;
- 12 (vi) *One – two ounce bag of absorbent powder*;
- 13 (vii) *One bag*;
- 14 (viii) *One scoop*; and
- 15 (ix) *One small scraper*;
- 16 [(e)] (c) [A backboard] *Backboard* designed for medical emergency use that is equipped with
- 17 straps and head immobilizer;
- 18 [(f)] (d) [A light] *Light*, strong rescue pole not less than 10 feet long; and
- 19 [(g)] (e) [A rescue] *Rescue* tube designed for lifesaving for each required lifeguard;
- 20 (2) [Except as set forth in §A(3) of this regulation, a] [public] *Public spa, semipublic spa or*
- 21 *public spray ground* is provided with the safety equipment required [in §A(1)(a)— (e)] *by*
- 22 *§A(1)(a)—(c) of this regulation; and*
- 23 (3) [A semipublic spa is provided with the safety equipment required in §A(1)(a)—(d) of this
- 24 regulation; and
- 25 (4) A semipublic] *Semipublic* pool is provided with a:

## Draft Regulations for COMAR 10.17.01 – Aquatic Facilities and Venues

- 1 (a) Light, strong rescue pole not less than 10 feet long; and
- 2 (b) Ring buoy or similar approved floatation device with an attached throwing rope measuring 50  
3 feet in length or  $[1\frac{1}{2}]$  1.5 times the width of the pool, whichever is longer.
- 4 B. Telephone. An owner shall ensure that, in case of an emergency, a telephone is available  
5 within the [pool or spa enclosure] *aquatic venue barrier* to individuals using [a public pool or  
6 spa] *an aquatic venue* that:
- 7 (1) *For a recreational pool, public spa, or public spray ground:*
- 8 (a) Can directly reach a 911 emergency service without the use of a coin and without connection  
9 to an internal switchboard;
- 10 [(2)] (b) Is posted with:
- 11 [(a)] (i) The names and phone numbers of the nearest available police, fire, and ambulance or  
12 rescue unit; or
- 13 [(b)] (ii) 911 or with any numbers necessary to reach a 911 emergency service center directly;  
14 and
- 15 [(3)] (c) Is posted with the name and [location of the pool or spa facility.] *physical address of the*  
16 *aquatic venue; and*
- 17 (2) *For a semipublic pool:*
- 18 (a) *Except for a guarded pool that is compliant with §B(1) of this regulation, can directly reach*  
19 *a 911 emergency service without dialing, the use of a coin, and without connection to an internal*  
20 *switchboard; and*
- 21 (b) *Complies with §B(1) of this regulation.*
- 22 C. Lifeguard Chair.
- 23 (1) An owner shall ensure that a recreational pool is equipped with lifeguard chairs in  
24 compliance with the American National Standard for Public Swimming Pools.
- 25 (2) An owner may use a deck-level lifeguard chair in a designated area on the deck adjacent to  
26 shallow water instead of an elevated lifeguard chair.
- 27 D. Lifeguards.
- 28 (1) An owner of a public pool shall comply with:

## Draft Regulations for COMAR 10.17.01 – Aquatic Facilities and Venues

- 1 (a) Local codes requiring lifeguards if the requirements of the local codes are stricter than the  
2 requirements set forth in §D(2)—(5) of this regulation; or
- 3 (b) §D(2)—(5) of this regulation if no local codes exist, or if the local codes requiring lifeguards  
4 are not as strict as the requirements of §D(2)—(5) of this regulation.
- 5 (2) Except as set forth in §D(1) and (3) of this regulation, an owner of a recreational pool shall  
6 have at least one lifeguard on duty on the deck observing the pool while [an individual is in the  
7 pool] *patrons are inside the pool barrier*, and shall have at the pool:
- 8 (a) Lifeguards who are appropriately trained and certified for the type of facility and activity in  
9 the pool;
- 10 (b) A sufficient number of lifeguards so that a lifeguard is on duty for each group of 50  
11 individuals, or fraction thereof, in the pool; and
- 12 (c) In addition to the number of lifeguards required [in] *by* [§D(2)(b)] §D(2) of this regulation,  
13 additional lifeguards on duty if:
- 14 (i) The shape, dimensions, layout, use, activities, or features of the pool create potential safety  
15 hazards;
- 16 (ii) The vision of the required lifeguard or lifeguards is obstructed;
- 17 (iii) The capabilities of the individuals using the pool are substandard; or
- 18 (iv) Another condition exists that compromises the ability of a lifeguard to monitor the pool.
- 19 (3) An owner may use a lifeguard on the deck of a swimming pool to monitor an adjacent  
20 wading pool, but if a wading pool is the only pool at a facility or if the wading pool cannot be  
21 observed from the deck of the swimming pool, the owner shall ensure that lifeguards are  
22 provided at the wading pool in accordance with §D(1) and (2) of this regulation.
- 23 (4) In addition to meeting the other requirements of this chapter, an owner or operator of [a] *an*  
24 *aquatic* facility specified in the following paragraphs shall ensure that a:
- 25 (a) Limited public-use pool has water safety supervision for pool activities in compliance with  
26 Regulation .15 of this chapter;
- 27 (b) Child care center has water safety supervision for pool activities at a child care center in  
28 compliance with COMAR [07.04.02.41] *13A.15.08.04*; and
- 29 (c) Youth camp has water safety supervision for pool activities at a youth camp in compliance  
30 with COMAR 10.16.06.
- 31 (5) The owner may only use or employ a lifeguard who holds a valid lifeguard certification from:

## Draft Regulations for COMAR 10.17.01 – Aquatic Facilities and Venues

- 1 (a) The American Red Cross;
- 2 (b) The Boy Scouts of America, not including a lifesaving merit badge;
- 3 (c) The Young Men's Christian Association;
- 4 (d) Ellis and Associates' National Pool and Waterpark Lifeguard Training; or
- 5 (e) An organization that has a lifeguard training program equivalent to the American Red Cross
- 6 lifeguard training.
  
- 7 (6) Except as set forth in §D(1) and (3) of this regulation, an owner of a semipublic pool that has
- 8 a water surface area greater than 2,500 square feet or that is part of a multiple pool facility within
- 9 one enclosure that has a combined water surface area greater than 2,500 square feet shall ensure
- 10 that at least one lifeguard is on duty on the deck observing a pool *at all times patrons are within*
- 11 *the pool barrier and* in the ratio of one guard per 50 individuals in the water :
  
- 12 (a) During the peak seasonal use of the pool from Memorial Day to Labor Day; and
- 13 (b) During the use of an indoor, heated pool throughout the entire year.
  
- 14 E. CPR and First-Aid Personnel. Except at a *semipublic pool or semipublic spa*, an owner of [a
- 15 recreational pool, public spa, and a limited public use pool] *an aquatic venue* shall ensure that:
  
- 16 (1) When the [pool or spa] *aquatic venue* is open for use, an individual is present and on site,
- 17 holding a valid certification for:
  
- 18 (a) Infant/child/adult or professional rescuer [cardiopulmonary resuscitation (CPR)] *CPR*; and
- 19 (b) First aid; and
  
- 20 (2) The CPR and first aid certifications of the individual required [in] *by* §E(1) of this regulation
- 21 are from:
  
- 22 (a) A national organization offering certification in CPR or first aid, such as the:
  
- 23 (i) American Red Cross;
- 24 (ii) American Heart Association; or
- 25 (iii) National Safety Council;
  
- 26 (b) The Emergency Medical Services; or
  
- 27 (c) An organization that has a certification program in CPR or first aid that is approved by one of
- 28 the organizations listed in §E(2) of this regulation.



## Draft Regulations for COMAR 10.17.01 – Aquatic Facilities and Venues

- 1 F. Safety Signs. An owner of [a public pool or spa] *an aquatic venue* shall ensure that:
- 2 (1) The size, color, design, application, symbol, and visual layout of a safety sign is in  
3 compliance with the ANSI Z-535 series of standards for Safety Signs and Colors as referenced in  
4 American National Standard for Public Spas;
- 5 (2) A spa safety sign is posted in a permanent location adjacent to a spa in compliance with the  
6 American National Standard for Public Spas;
- 7 (3) The spa safety sign includes the user load of the spa;
- 8 (4) A chemical warning sign is posted at the entrance door to a chemical storage area and  
9 includes the text "Caution! Chemical Storage Area";
- 10 (5) A chemical vat, feeder, pump, and line is labeled to identify the chemical in use;
- 11 (6) A chlorine gas warning sign reading "Danger—Chlorine Gas" is posted at the entrance to a  
12 chlorine gas feed room and storage area;
- 13 (7) Other warning, health advisory, and safety signs are posted if necessary to protect the public  
14 health and safety, for example, "Danger! No Diving In Shallow Water";
- 15 (8) A semipublic pool [or public spa] that does not have a lifeguard on duty has a conspicuous  
16 sign posted adjacent to entrances to the pool [or spa] reading "WARNING; NO LIFEGUARD  
17 ON DUTY. **SWIM AT YOUR OWN RISK.** DO NOT SWIM ALONE. CHILDREN UNDER  
18 15 SHOULD NOT USE THE POOL WITHOUT ADULT SUPERVISION."; [and]
- 19 (9) House rules are posted at the entrance to [a pool or spa.] *an aquatic venue*; *and*
- 20 (10) *A conspicuous sign posted adjacent to entrances to the aquatic venue reading, "Use of a*  
21 *public pool, spa or spray ground is prohibited if you have an infectious or contagious disease*  
22 *that may be transmitted through water, an open cut, blister, other lesion or diarrhea."*

### Summary of changes:

#### MAHC:

#### Relevant comments:

- 2015-086                      2015-087
- 2015-088                      2015-107
- 2017-041                      2017-078
- 2017-114                      2017-115
- 2017-116                      2017-117
- 2017-118                      2017-241
- 2017-242

Draft Regulations for COMAR 10.17.01 – Aquatic Facilities and Venues

1 **.41 [Pool and Spa] Aquatic Venue Operator Certification.**

2 A. A person may not act as or perform the duties of [a public pool or spa] *an aquatic venue*  
3 operator without [a pool and spa] *an aquatic venue* operator certification card issued by the  
4 Secretary as required [in] *by* §§B and [G] *I* of this regulation.

5 B. [The Secretary shall issue a 3-year public pool and spa operator certification card only to an  
6 individual 16 years old or older who has:

7 (1) Completed a 14-hour approved public pool and spa operator's course or a course offered by  
8 the Secretary with a minimum grade of 70 percent on an approved written examination given  
9 following the completion of that course; or

10 (2) Presented proof of previous certification and has:

11 (a) Completed an approved 4-hour refresher course; or

12 (b) Passed a challenge exam offered by the Secretary.] *The Secretary shall issue an aquatic*  
13 *venue operator certification card to an individual who:*

14 (1) *Is 16 years old or older; and*

15 (2) *Has:*

16 (a) *Completed a 14 hour aquatic venue operator's course approved by the Secretary and passed,*  
17 *with a minimum grade of 75 percent, a written exam approved by the Secretary; or*

18 (b) *Presented a current aquatic venue operator certification card and has:*

19 (i) *Completed a 4 hour refresher course approved by the Secretary, and passed, with a minimum*  
20 *grade of 75 percent, a written exam approved by the Secretary; or*

21 (ii) *Passed, with a minimum grade of 75 percent, a challenge exam offered by the Secretary.*

22 C. *An individual who fails an exam, required by §B(2) of this regulation, may retake the exam*  
23 *one time before having to take the course and pass the exam.*

24 D. *An aquatic venue operator's certification card shall be valid for 3 years from the date the*  
25 *individual complies with §B(2) of this regulation.*

26 [C.] E. The Secretary may summarily suspend [a pool and spa] *an aquatic venue* operator's  
27 certification *card* if the operator does not comply with Regulation .43 of this chapter.

28 [D.] F. Hearing for Summary Suspension. In the case of the summary suspension of certification  
29 pursuant to [§C]§E of this regulation, the Secretary shall provide the certification card holder

## Draft Regulations for COMAR 10.17.01 – Aquatic Facilities and Venues

1 with written notice of the suspension and an opportunity for a hearing pursuant to State  
2 Government Article, Title 10, Subtitle 2, Annotated Code of Maryland.

3 [E.] G. To preserve the right to a hearing, the certification card holder shall contact the Secretary  
4 within [30]10 calendar days of the receipt of the notice of the suspension.

5 [F.] H. The Secretary shall recognize [a pool and spa] *an aquatic venue* operator certification as  
6 valid throughout the State.

7 [G.] I. The Secretary shall issue [a 3-year limited public-use pool operator certification card to an  
8 individual 16 years old or older who has completed:

9 (1) An approved 4-hour limited public-use pool operator's course and passed an approved written  
10 examination with a minimum grade of 75 percent following completion of the course; or

11 (2) The requirements of §B of this regulation.] *a limited public-use pool operator certification*  
12 *card to an individual who:*

13 (1) *Is 16 years old or older; and*

14 (2) *Has:*

15 (a) *Completed a 4 hour limited public-use pool operator's course approved by the Secretary and*  
16 *passed with a minimum grade of 75 percent, a written exam approved by the Secretary; or*

17 (b) *Met the requirements of §B of this regulation.*

18 [H.] J. An individual who possesses [a public pool and spa] *an aquatic venue* operator  
19 certification card may perform the duties of [a public pool and spa] *an aquatic venue* operator at  
20 [a limited public-use, recreational, and semipublic pool and public spa] *any aquatic venue*. An  
21 individual who possesses a limited public-use pool operator certification card may perform the  
22 duties of a limited public-use pool operator only at a limited public-use pool.

### Summary of changes:

#### MAHC:

#### Relevant comments:

- 2015-089                      2017-042
- 2017-043                      2017-065
- 2017-079                      2017-119
- 2017-120                      2017-147
- 2017-243                      2017-244

## Draft Regulations for COMAR 10.17.01 – Aquatic Facilities and Venues

### 1 **.42 Approval of Operator's Course.**

2 The Secretary shall approve [a pool and a spa] *an aquatic venue* operator's course based on the  
3 following criteria:

4 A. An approved course shall cover general aspects of [public pool and spa] *aquatic venue*  
5 operation including:

6 (1) [Applicable regulations,] *State and local regulations;*

7 (2) Disease prevention[,], *which shall cover CT values, recreational water infections (RWI), and*  
8 *response to formed-stool, diarrhea, blood, and vomit in and around an aquatic venue;*

9 (3) Disinfection[,], *which shall cover sanitation, cyanuric acid, non-chlorine oxidizers, combine*  
10 *chlorine, breakpoint chlorination, and alternate and supplemental systems;*

11 (4) Filtration[,], *which shall cover types of filters, normal operation, filter backwashing, cleaning,*  
12 *and pressure;*

13 (5) *Circulation which shall cover turnover rates and flow rates;*

14 [(5)] (6) Circulation system components, operation, and maintenance[,];

15 [(6)] (7) General [pool and spa] *aquatic venue maintenance and cleaning equipment*[,

16 (7) Operation and maintenance of equipment,];

17 (8) Water chemistry[,], *which shall cover water balance, saturation index, and dosing;*

18 (9) Water testing[,], *which shall cover testing methods and frequency;*

19 (10) Record keeping and required reporting[,];

20 (11) [General pool and spa] *Other aquatic venue chemicals*[,], *which shall cover water clarifiers,*  
21 *stain and scale inhibitors, enzymes, oxidizers, algae prevention, problems related to green hair,*  
22 *and other issues;*

23 [(12) Chemical handling,] *Other Aquatic Venues which shall cover spas and spray grounds;*

24 (13) Waste water disposal[,];

25 (14) Safety[,], *which shall cover risk management and reduction, the Virginia Graeme Baker*  
26 *Pool and Spa Safety Act (VGB), gates and entry to the aquatic venue, barriers, chemical*  
27 *handling, spills, storage and disposal, safety equipment, and spa shut-off switch; and*

28 (15) [Sanitation, and

## Draft Regulations for COMAR 10.17.01 – Aquatic Facilities and Venues

- 1 (16)] Other pertinent topics as specified by the Secretary[; and].
- 2 B. An approved course shall be taught by an individual who has demonstrated to the Secretary:
- 3 (1) Expertise in the operational aspects listed in §A of this regulation, as evidenced by combined  
4 work experience, training, and formal education[, and];
- 5 (2) Successful completion of an approved [public pool and spa] *aquatic venue* operator's course;  
6 *and*
- 7 (3) *Current certification according to Regulation .41.*
- 8 C. *An individual approved to teach according to §B of this regulation may conduct the course*  
9 *online provided an individual taking the course completes the written examination required by*  
10 *Regulation .41 of this chapter in person.*

### Summary of changes:

#### MAHC:

#### Relevant comments:

- 2015-009
- 2015-060
- 2015-090
- 2017-121
- 2017-245

### 11 **.43 [Pool and Spa] Aquatic Venue Operation.**

12 An owner shall ensure that a certified [pool and spa] *aquatic venue* operator:

13 A. Is on site at all times when a recreational pool is open;

14 B. Is available at a semipublic pool, public spa, [and at a] limited public-use pool, *and public*  
15 *spray ground* for performance of all requirements of this chapter and is able to [respond to  
16 operational problems] *arrive at the aquatic venue* within 15 minutes when not available on site;

17 C. Measures and records[, or supervises and verifies the measurement and recording of,] all  
18 information required [in] *by Regulation .46 of this chapter;*

19 D. Performs all duties related to the operation of [a pool or spa] *an aquatic venue* as required [in]  
20 *by this chapter;*

## Draft Regulations for COMAR 10.17.01 – Aquatic Facilities and Venues

- 1 E. Cleans the filtration system when the filter pressure differential reaches a level specified by
- 2 the equipment's manufacturer or as specified below:
  - 3 (1) High rate sand filters at 15 psi[.];
  - 4 (2) Rapid rate sand filters at 8 psi[.];
  - 5 (3) Cartridge filters at 10 psi[.];
  - 6 (4) Pressure diatomaceous earth filters at 10 psi[.]; and
  - 7 (5) Vacuum diatomaceous earth filters at 15 inches of mercury;
- 8 F. Maintains disinfection residuals according to Regulation .44 of this chapter;
- 9 G. Maintains water chemistry according to Regulation .45 of this chapter; [and]
- 10 H. Adds, *while the aquatic venue is closed*, a [nonstabilized] *non-stabilized* oxidizer into the
- 11 [pool or spa] *aquatic venue* water equivalent to an amount of free chlorine equal to at least 10
- 12 times the measured combined chlorine residual plus sufficient free chlorine to oxidize the
- 13 ammonia and nitrogenous compounds in the water, on a [recommended] schedule of once per
- 14 week for a pool and once per day for a wading pool [and for a], spa[.]*or spray ground; and*
- 15 I. *Documents the:*
  - 16 (1) *Date;*
  - 17 (2) *Time;*
  - 18 (3) *Combined chlorine residual, in ppm, prior to adding the oxidizer;*
  - 19 (4) *The amount of non-stabilized oxidizer added to the aquatic venue; and*
  - 20 (5) *The combined chlorine residual, in ppm, after adding the oxidizer.*

### Summary of changes:

#### MAHC:

#### Relevant comments:

- 2015-025
- 2017-122
- 2017-246
- 2017-247

Draft Regulations for COMAR 10.17.01 – Aquatic Facilities and Venues

1 **.44 Disinfection of [a Pool and Spa] *an Aquatic Venue.***

2 A. An owner or operator of [a public pool or spa] *an aquatic venue* shall ensure that [a]:

3 *(1) A primary* disinfectant [or combination of disinfectants] is added to the water automatically  
4 through an approved chemical feeder to maintain [continuously] a residual level as specified  
5 below:

6 [(1) Free] *(a) Except as provided by §A(1)(b) of this regulation, free chlorine shall be between:*

7 [(a)] *(i) 1.5 ppm and [10.0] 10 ppm in pools for swimming and diving and water recreational*  
8 *attractions;*

9 [(b)] *(ii) [3.0] 3 ppm and [10.0] 10 ppm in pools for wading or therapy or for a public spray*  
10 *ground; and*

11 [(c)] *(iii) [4.0] 4 ppm and [10.0] 10 ppm in spas;*

12 *(b) For an aquatic venue where ORP is maintained above 680 and monitored by an approved*  
13 *automatic controller, free chlorine shall be between:*

14 *(i) 1 ppm and 10 ppm in pools for swimming and diving and water recreational attractions;*

15 *(ii) 2.5 ppm and 10 ppm in pools for wading or therapy or for a public spray ground; and*

16 *(iii) 3.5 ppm and 10 ppm in spas;*

17 [(2)]*(c) The maximum amount of combined chlorine shall be [0.2] 0.4 ppm for all [pools and*  
18 *spas] aquatic venues;*

19 [(3) Total]*(d) Except as provided in §A(1)(e) of this regulation, total bromine shall be between:*

20 [(a)] *(i) [3.0] 3 ppm and [8.0] 10 ppm in pools for swimming and diving and water recreational*  
21 *attractions; and*

22 [(b)] *(ii) [4.0] 4 ppm and [8.0] 10 ppm in spas [and in], pools for wading or therapy, and public*  
23 *spray grounds; and*

24 *(e) For an aquatic venue where ORP is maintained above 680 and monitored by an approved*  
25 *automatic controller, total bromine shall be between:*

26 *(i) 2 ppm and 10 ppm in pools for swimming and diving and water recreational attractions; and*

27 *(ii) 3 and 10 ppm in spas, pools for wading or therapy, and public spray grounds; and*

## Draft Regulations for COMAR 10.17.01 – Aquatic Facilities and Venues

- 1 (2) For an aquatic venue using supplemental disinfectant in conjunction with a primary  
2 disinfectant that:
- 3 [(4) For pools and spas] (a) For an aquatic venue using copper and silver ions [as a secondary  
4 disinfectant in conjunction with chlorine or bromine as a primary disinfectant]:
- 5 [(a)] (i) Copper ions shall be between 0.2 ppm and [1.0] 1 ppm;
- 6 [(b)] (ii) Silver ions may not exceed 0.05 ppm;
- 7 [(c) Free] (iii) In pools for swimming and diving and water recreational attractions, chlorine in  
8 combination with copper and silver ions shall be between[:
- 9 (i) 0.5 ppm and 10 ppm [in pools for swimming and diving and water recreational attractions,  
10 and];
- 11 [(ii)] (iv) In spas, pools for wading or therapy, and public spray grounds, chlorine in  
12 combination with copper and silver ions shall be between 1.5 ppm and [10.0] 10 ppm [in spas  
13 and in a pool for wading or therapy; and];
- 14 [(d) Total bromine in combination with copper and silver ions shall be between:
- 15 (i) (v) In pools for swimming and diving and water recreational attractions, total bromine in  
16 combination with copper and silver ions shall be between [1.0] 1 ppm and [8.0 ppm in pools for  
17 swimming and diving and water recreational attractions,] 10 ppm; and
- 18 [(ii)] (vi) In spas, pools for wading or therapy, and public spray grounds, total bromine in  
19 combination with copper and silver ions shall be between [3.0] 3 ppm and [8.0 ppm in spas and  
20 pools for wading or therapy] 10 ppm;
- 21 [(5)] (b) For [pools and spas] aquatic venues using an ozone generator, the maximum amount of  
22 ozone measured 2 inches [above] below the water surface shall be 0.1 ppm;
- 23 [(6)] (c) For [pools] an aquatic venue using PHMB, the minimum level of PHMB shall be 30  
24 ppm; and
- 25 [(7)] (d) For [pools and spas] an aquatic venue using an ultraviolet light/hydrogen peroxide  
26 system, the minimum level of hydrogen peroxide shall be 20 ppm.
- 27 B. An owner or operator shall ensure that for [public pools and spas] an aquatic venue using  
28 cyanuric acid or a similar chlorine stabilizer, the cyanuric acid or similar chlorine stabilizer is  
29 maintained [between 30 ppm and 100] at less than 50 ppm.
- 30 C. An owner or operator of [a public pool or spa] an aquatic venue may not use:
- 31 (1) PHMB in [a pool or spa] an aquatic venue that uses jets or sprays;



## Draft Regulations for COMAR 10.17.01 – Aquatic Facilities and Venues

- 1 (2) PHMB in conjunction with [any]:
- 2 (a) Any halogen compound [or ozone]; *or*
- 3 (b) *Ozone*;
- 4 (3) Cyanuric acid in conjunction with [a]:
- 5 (a) A bromine compound [or in]; *or*
- 6 (b) At an indoor [pool or spa] *aquatic venue*; *or*
- 7 (4) An ultraviolet light/hydrogen peroxide system in conjunction with a diatomaceous earth
- 8 filter.

### Summary of changes:

#### MAHC:

#### Relevant comments:

- 2015-026
- 2015-039
- 2015-091
- 2017-044
- 2017-123
- 2017-148

### 9 **.45 Water Chemistry of [a Pool and Spa] *an Aquatic Venue*.**

10 A. An owner or operator shall ensure that the water chemistry of [a public pool or spa] *an*  
11 *aquatic venue* is maintained according to the following requirements:

- 12 (1) The pH of the water is maintained between 7.2 and 7.8;
- 13 (2) The total alkalinity of the water is maintained between 60 ppm and 180 ppm;
- 14 (3) [The] *Except for spas*, calcium hardness of the water is maintained between 150 *ppm* and  
15 [400] *1,000* ppm;
- 16 (4) [The Langelier Saturation Index of the water is maintained between -0.5 and +0.5 as  
17 calculated by:] *For spas, calcium harness of the water is maintained between 100 ppm and 800*  
18 *ppm*;

## Draft Regulations for COMAR 10.17.01 – Aquatic Facilities and Venues

1 (5) *The Langelier Saturation Index of the water is maintained between -0.3 and +0.5 as*  
 2 *calculated by:*

3 (a) The Langelier Saturation Index formula:  $Langelier\ Saturation\ Index = pH + TF + CF + AF -$   
 4  $[12.1\ where:\ TF = temperature\ factor,\ CF = calcium\ hardness\ factor,\ and\ AF = alkalinity\ factor,$   
 5  $and]\ TDSF;$  *and*

6 (b) The following factor table:

Temperature (°F)	Temperature Factor	Calcium Hardness (ppm)	Calcium Factor	Total Alkalinity (ppm)	Alkalinity Factor	Total Dissolved Solids (ppm)	Total Dissolved Solids Factor
32	0.0	5	0.3	5	0.7	<1000	12.10
37	0.1	25	1.0	25	1.4	1000-1999	12.19
46	0.2	50	1.3	50	1.7	2000-2999	12.29
53	0.3	75	1.5	75	1.9	3000-3999	12.35
60	0.4	100	1.6	100	2.0	4000-4999	12.41
66	0.5	150	1.8	150	2.2	5000-5999	12.44
76	0.6	200	1.9	200	2.3		
84	0.7	300	2.1	300	2.5		
94	0.8	400	2.2	400	2.6		
105	0.9	800	2.5	800	2.9		
128	1.0	1000	2.6	1000	3.0		

7 [(5) The] (6) *Except for an aquatic venue utilizing an electrolytic chlorine generator, the amount*  
 8 *of total dissolved solids is maintained so that it does not exceed 1,500 ppm[, except for a salt*  
 9 *water pool where the total dissolved solids may not exceed 3,000 ppm];*

10 (7) *For an aquatic venue utilizing an electrolytic chlorine generator, the amount of total*  
 11 *dissolved solids is maintained so that it does not exceed 1,500 ppm above the starting value of*  
 12 *the total dissolved solids as documented on the aquatic venue's data sheet for the aquatic venue*  
 13 *when balanced; and*

14 (8) *The starting value of the total dissolved solids for the aquatic venue is updated whenever the*  
 15 *aquatic venue is drained and filled;*

16 [(6)] (9) The amount of dissolved metals is maintained so that it does not exceed the following  
 17 levels:

18 (a) Iron, 0.3 ppm[,];

19 (b) Manganese, 0.3 ppm[,]; and

20 (c) Copper, 1.3 ppm; and

## Draft Regulations for COMAR 10.17.01 – Aquatic Facilities and Venues

1 [(7)] (10) The water clarity is maintained so that either a 6 inch seechi disc placed in the deepest  
2 part of [a pool or spa] *an aquatic venue* or the main drain is clearly visible and sharply defined  
3 when observed from the side of [the pool or spa] *an aquatic venue*.

4 B. An owner or operator shall ensure that:

5 (1) Water additives and treatment chemicals are used according to manufacturers' instructions;  
6 and

7 (2) When chemicals are added directly to [a pool or spa] *an aquatic venue*, no one is allowed in  
8 the water *during dispersion* or until the chemicals are dissolved and diffused throughout [the  
9 pool or spa] *an aquatic venue*.

10 C. An owner or operator shall ensure that the water temperature for a *mechanically* heated  
11 [public pool or spa does not exceed] *aquatic venue does not exceed*:

12 (1) 88°F for a pool *or spray ground*;

13 (2) 104°F for a spa; and

14 (3) 96°F for a therapy pool[.] *for a pool meeting the turnover rate for a therapy pool as required*  
15 *by Regulation .25B and the disinfection of a therapy pool as required by Regulation .44 of this*  
16 *chapter*.

### Summary of changes:

#### MAHC:

#### Relevant comments:

- 2015-010
- 2015-061
- 2017-045
- 2017-124
- 2017-149
- 2017-150

### 17 **.46 Operating Records Required.**

18 *An aquatic venue* operator shall maintain operating records on a form provided by the Secretary  
19 or an equivalent form and shall:

20 A. Except as provided in §B of this regulation, record the information required [in] *by*:

21 (1) §C(1)—(3) of this regulation in:

Draft Regulations for COMAR 10.17.01 – Aquatic Facilities and Venues

1 (a) 2[-] hour intervals for a recreational pool [and for a], public spa, [and three] *or public spray*  
2 *ground; or*

3 (b) *Three* times per day for a limited public-use [and] *pool*, semipublic pool; and [record the  
4 information required in]

5 (2) [§C(4)— (9)] §C(4)—(10) of this regulation [a minimum of three times per day for a public  
6 pool and spa,] *in intervals no less than 2 hours and no more than 4 hours apart for an aquatic*  
7 *venue* beginning [1/2 hour before] *prior to* opening;

8 B. For [a public pool or spa] *an aquatic venue* where an approved automatic controller is used,  
9 record the information required [in] *by* §C of this regulation:

10 (1) [A minimum of three times per day in conformance with the following schedule:

11 (a) The first recording of the day shall be made 1/2 hour before the pool or spa opens,

12 (b) The second recording shall be completed between 12 p.m. and 2 p.m., and

13 (c) The final recording shall be completed 2 hours before closing] *In intervals no less than 2*  
14 *hours and no more than 4 hours apart; and*

15 (2) More frequently if required by the Secretary due to conditions such as high bather load, high  
16 temperatures, bright sunlight, or inadequate water quality;

17 C. Record the following information in the intervals required [in] *by* §§A and B of this  
18 regulation:

19 (1) Disinfectant residual *in ppm;*

20 (2) Combined chlorine level *in ppm*, if chlorine is used;

21 (3) pH;

22 (4) Water clarity;

23 (5) Water temperature *in degrees Fahrenheit*, if heated;

24 (6) Flow rate *in gpm;*

25 (7) Filter influent pressure and effluent pressure *in PSI;*

26 (8) Pump vacuum *in PSI;* [and]

27 (9) Total number of bathers; *and*

Draft Regulations for COMAR 10.17.01 – Aquatic Facilities and Venues

1 (10) If the aquatic venue is equipped with an automatic controller, ORP and pH readings from  
2 the automatic controller;

3 D. Record in 1[-] week intervals for a public pool and in 1[-] day intervals for a public spa or  
4 spray ground:

5 (1) Total alkalinity level *in ppm*;

6 (2) Calcium hardness level *in ppm*; and

7 (3) Cyanuric acid level *in ppm*, if used;

8 E. Record daily for [a public pool or spa] *an aquatic venue*:

9 (1) The time of filter backwash or cleaning;

10 (2) An injury or accident at [the pool or spa] *an aquatic venue*;

11 (3) Chemicals added to the water; [and]

12 (4) *For a spa*:

13 (a) *The water replacement interval*;

14 (b) *The interval between the last water change; and*

15 (c) *The difference between the water replacement interval and the interval between the last water*  
16 *change; and*

17 (5) Malfunctioning or broken equipment;

18 F. Date and sign each record sheet *and initial each entry*;

19 G. [Record] *Each day prior to opening the aquatic venue record the results of the following*  
20 *inspections [in the specified intervals] to complete [a Pool and Spa Entrapment] an Aquatic*  
21 *Venue Hazards Checklist*:

22 [(1) Daily check before the facility is open to verify that:

23 (a) Drain covers, vacuum fitting covers, skimmer equalizer covers, and any other suction outlet  
24 covers are in place, secure, and unbroken,

25 (b) Skimmer baskets, weirs, lids, flow adjusters, and suction outlet lines are free of any blockage,

26 (c) Inlet and return covers or fittings are in place, secure, and unbroken,

## Draft Regulations for COMAR 10.17.01 – Aquatic Facilities and Venues

- 1 (d) Safety warning signs are in place around the pool or spa, including emergency instructions  
2 and phone numbers, and
- 3 (e) On/off switches for pumps are clearly labeled and the location of the pumps is clearly  
4 identified; and
- 5 (2) Check all information required in §G(1) of this regulation before filling a pool or spa with  
6 water, after periodic maintenance, and after pool or filter cleaning procedures;]
- 7 (1) *Suction outlet covers are:*
- 8 (a) *Secure; and*
- 9 (b) *Free from breaks, cracks, or defects;*
- 10 (2) *Skimmers are:*
- 11 (a) *Free from any blockage; and*
- 12 (b) *Equipped with:*
- 13 (i) *Secure lids; and*
- 14 (ii) *Functioning weirs;*
- 15 (3) *Inlet and return covers are:*
- 16 (a) *In place;*
- 17 (b) *Secure; and*
- 18 (c) *Unbroken;*
- 19 (4) *Warning signs are in place;*
- 20 (5) *The on/off switch to each pump is clearly labeled;*
- 21 (6) *If an aquatic venue is equipped with a suction vacuum release system, that the suction*  
22 *vacuum release system releases suction when tested;*
- 23 (7) *The circulation pump is running;*
- 24 (8) *The flow rate for the aquatic venue is between the minimum and maximum turnover rate; and*
- 25 (9) *The certified operator has verified compliance and signed or initialed the checklist.*

## Draft Regulations for COMAR 10.17.01 – Aquatic Facilities and Venues

- 1 H. Keep the records on [the premises] *file* for a minimum of 3 years; and
- 2 I. Submit the records to the Secretary upon request.

### Summary of changes:

#### MAHC:

#### Relevant comments:

- 2015-062
- 2015-092
- 2015-093
- 2017-046
- 2017-076
- 2017-125
- 2017-126
- 2017-151
- 2017-152
- 2017-248

### 3 **.47 Test Kits.**

4 A. In order to comply with the requirements of Regulation .46 of this chapter, an owner shall  
5 ensure that:

6 (1) One or more of the following for measuring the disinfectant level is used:

7 (a) A chlorine or bromine test kit that is the DPD [(diethyl-p-phenylene diamine)] reagent system  
8 for measuring free and combined chlorine or total bromine with an indicator range from 0.0 to  
9 10.0 ppm or with procedures for performing a dilution test to achieve readings up to 10.0 ppm[.];

10 (b) An ozone test kit that is the indigo trisulfonate method for measuring ozone with an indicator  
11 range from [0.0] 0 to [1.0] 1 ppm[.];

12 (c) A copper test kit that is accurate to within +/- 0.1 ppm for measuring copper[.];

13 (d) A PHMB test kit with an indicator range from [0.0] 0 ppm to 75 ppm[.];or

14 (e) A hydrogen peroxide test kit that is the DPD reagent system with an indicator range from  
15 [0.0] 0 to 40 ppm;

16 (2) A phenol red test is used to measure pH with an indicator range from at least 7.0 to 8.0;

## Draft Regulations for COMAR 10.17.01 – Aquatic Facilities and Venues

1 (3) An alkalinity titration test is used to measure alkalinity as milligrams per liter calcium  
2 carbonate;

3 (4) An EDTA [(ethylenediamine-tetraacetate)] hardness test is used to measure calcium hardness  
4 as milligrams per liter calcium carbonate; and

5 (5) A cyanuric acid test kit with an indicator range from 0 to 100 ppm is used if cyanuric acid is  
6 used in the pool [or], spa *or spray ground*.

7 B. In order to comply with the requirements of Regulation .46 of this chapter, an owner may  
8 monitor:

9 (1) Chlorine and bromine residuals by measuring the [oxidation-reduction potential (ORP)] *ORP*  
10 of the water before the disinfectant injection point; and

11 (2) The pH with a pH meter.

12 C. If an ORP or pH meter is used, an owner shall ensure that:

13 (1) Periodic calibration is performed on these instruments to assure accurate measurements;  
14 [and]

15 (2) *Documentation of calibrations are:*

16 (a) *Kept on file for 3 years; and*

17 (b) *Made available to the Department upon request; and*

18 (3) Manual measurements are performed on a daily basis.

### Summary of changes:

#### MAHC:

#### Relevant comments:

- 2017-127
- 2017-153
- 2017-154

### 19 **.48 Sanitary Quality of Water.**

20 A. Although routine testing is not required, an owner *or operator* shall ensure that the water in [a  
21 public pool or spa] *an aquatic venue*:

22 [A.] (1) Has a coliform bacteria level of less than 1 coliform per milliliter; [and]



## Draft Regulations for COMAR 10.17.01 – Aquatic Facilities and Venues

1 [B.] (2) Is free of pathogenic organisms[.]; and

2 (3) Is tested after a fecal or vomit incident.

3 B. An owner or operator shall:

4 (1) Contact either the local health department or a Maryland certified laboratory to test the  
5 water in an aquatic venue after completing the requirements in Regulation .48-1 of this chapter;

6 (2) Ensure that four samples of the water in an aquatic venue are collected from various points  
7 around the aquatic venue, including the general area where the incident occurred; and

8 (3) Immediately close the aquatic venue and repeat the requirements in Regulation .48-1 of this  
9 chapter if any sample has a coliform bacteria level that does not meet the requirements in  
10 §§A(1)—(2) of this regulation.

11 C. The Secretary may perform bacteriological testing of the water in an aquatic venue at anytime  
12 the aquatic venue is in operation.

13 D. If the Secretary determines that the water in an aquatic venue does not meet the requirements  
14 in §§A(1)—(2) of this regulation, the owner or operator shall immediately close the aquatic  
15 venue and perform the requirements in Regulation .48-1A of this chapter.

16 E. The owner or operator may not operate the aquatic venue until compliance with §§A(1)—(2)  
17 of this regulation is achieved.

### Summary of changes:

#### MAHC:

#### Relevant comments:

- 2017-047
- 2017-155
- 2017-249

18 ***.48-1 Fecal, Vomit, and Blood Incident Response at an Aquatic Venue***

19 *An owner or operator of an aquatic venue where:*

20 A. *A fecal or vomit incident has occurred shall:*

21 (1) *Immediately close the aquatic venue, and have patrons exit the venue;*

22 (2) *Remove as much of the fecal material or vomit as possible and dispose of it in a sanitary*  
23 *manner;*

Draft Regulations for COMAR 10.17.01 – Aquatic Facilities and Venues

- 1 (3) *Clean and disinfect the items used to remove the fecal material or vomit;*
- 2 (4) *Ensure pH is maintained at 7.5 or less;*
- 3 (5) *Ensure that the temperature is maintained at 77°F or higher;*
- 4 (6) *For a formed-stool fecal or vomit incident, maintain the free chlorine level at:*
  - 5 (a) *1 ppm for 45 minutes;*
  - 6 (b) *2 ppm for 23 minutes;*
  - 7 (c) *3 ppm for 15 minutes;*
  - 8 (d) *4 ppm for 11 minutes;*
  - 9 (e) *5 ppm for 9 minutes;*
  - 10 (f) *6 ppm for 8 minutes;*
  - 11 (g) *7 to 8 ppm for 6 minutes; or*
  - 12 (h) *9 to 10 ppm for 5 minutes;*
- 13 (7) *For a diarrheal fecal incident, maintain the free chlorine level at:*
  - 14 (a) *10 ppm for 25.5 hours;*
  - 15 (b) *15 ppm for 17 hours;*
  - 16 (c) *20 ppm for 13 hours;*
  - 17 (d) *25 ppm for 10.5 hours;*
  - 18 (e) *30 ppm for 8.5 hours;*
  - 19 (f) *35 ppm for 7.5 hours;*
  - 20 (g) *40 ppm for 6.5 hours;*
  - 21 (h) *45 ppm for 6 hours;*
  - 22 (i) *50 ppm for 5.5 hours; or*
  - 23 (j) *55 ppm for 5 hours;*

## Draft Regulations for COMAR 10.17.01 – Aquatic Facilities and Venues

1 (8) Record the incident in the Fecal, Vomit, and Blood Incident Response log as required by  
2 Regulation .51 of this chapter; and

3 (9) Test the water in the aquatic venue as required by Regulation .48 of this chapter; and

4 B. A blood incident has occurred shall:

5 (1) Immediately clean and disinfect the area around the aquatic venue contaminated by blood,  
6 utilizing the blood borne pathogen control kit required by Regulation .40 of this chapter;

7 (2) Measure the disinfectant level in the aquatic venue water to ensure it is compliant with  
8 Regulation .44 of this chapter; and

9 (3) Record the incident in the Fecal, Vomit, and Blood Incident Response log as required by  
10 Regulation .51 of this chapter.

### Summary of changes:

#### MAHC:

#### Relevant comments:

- 2015-014                      2015-028
- 2015-046                      2015-096
- 2015-109                      2017-048
- 2017-075                      2017-128
- 2017-129                      2017-130
- 2017-250

### 11 **.48-2 Water Replacement**

12 A. An operator of a public spa shall replace the entire volume of water within the public spa  
13 when the difference between the interval since the last water change and the WRI, as calculated  
14 according to §B of this regulation, is less than or equal to zero.

15 B. Water Replacement Interval.

16  $WRI$  (days rounded to the nearest whole number) =  $(1/3) \times (\text{spa volume in gallons}) / (\text{number of}$   
17  $\text{bathers since last water change})$ .

## Draft Regulations for COMAR 10.17.01 – Aquatic Facilities and Venues

- 1 C. Water loss due to evaporation may not be counted as water drained and replaced to meet the  
2 requirements of §§A or B of this regulation.

### Summary of changes:

#### MAHC:

#### Relevant comments:

- 2015-013                      2015-027
- 2015-040                      2015-042
- 2015-045                      2015-063
- 2015-094                      2015-095
- 2015-108                      2017-049
- 2017-059                      2017-131
- 2017-156                      2017-251

### 3 .49 Chemical Handling and Storage.

4 An owner shall ensure that a:

5 A. [Material safety] Safety data sheet for [a potentially hazardous] *each* chemical used at an  
6 aquatic venue is [available]:

7 (1) Available to the operator;

8 (2) Maintained within:

9 (i) A water proof cover; and

10 (ii) A 3 ring binder; and

11 (3) Is current;

12 B. Chemical is handled, used, stored, and disposed of in accordance with the [material] safety  
13 data sheet and all applicable federal, State, and local codes; [and]

14 C. Chemical is stored in a chemical storage area which is in compliance with Regulation .29 of  
15 this chapter[.]; and

16 D. An operator is provided with the:

17 (1) Personal protective equipment listed in the safety data sheet for each chemical used at the  
18 aquatic venue; and

## Draft Regulations for COMAR 10.17.01 – Aquatic Facilities and Venues

- 1 (2) *Training necessary to properly use the personal protective equipment listed in the safety data*  
2 *sheet for each chemical used at the aquatic venue.*

### Summary of changes:

#### MAHC:

#### Relevant comments:

- 2015-097
- 2017-050

### 3 **.50 Control of Infectious and Contagious Diseases.**

4 A. An owner may not knowingly permit an individual to enter the water of [a public pool or spa]  
5 *an aquatic venue* who has:

6 (1) An infectious or contagious disease that may be transmitted through water;

7 (2) An open cut, blister, or other lesion; or

8 (3) Diarrhea.

9 B. An owner or operator may not prohibit an individual from entering the water of [a public pool  
10 or spa] *an aquatic venue* if a physician certifies that the individual's condition is not infectious or  
11 contagious by waterborne transmission.

### Summary of changes:

#### MAHC:

#### Relevant comments:

- 

### 12 **.51 [Injury and Illness] *Aquatic Venue Incident Reports.***

13 [A public pool or spa] *An owner of an aquatic venue* shall ensure that:

14 A. An [injury, drowning, near drowning, or suction entrapment] *incident* occurring at [a pool or  
15 spa] *an aquatic venue* that results in death or that requires resuscitation or admission to a hospital  
16 is reported to the Secretary within 24 hours of the incident *on the Aquatic Venue Incident Report*  
17 *Form*;

Draft Regulations for COMAR 10.17.01 – Aquatic Facilities and Venues

1 B. [A waterborne] *An illness contracted at [a pool or spa] an aquatic venue* is reported to the  
2 Secretary within 24 hours of the owner's or operator's knowledge of the incident *on the Aquatic*  
3 *Venue Incident Report Form*;

4 C. [A water rescue] *Water rescues* by aquatic safety personnel [is] *are* reported to the Secretary  
5 every 3 months during operation or at the seasonal closure of [the facility] *an aquatic venue*,  
6 whichever is more frequent [; and], *on the Aquatic Venue Incident Report Form*;

7 D. The information required [in A-----C] by §§A—C of this regulation is [recorded on a pool and  
8 spa injury and illness report form provided by the Secretary] *recorded on the Aquatic Venue*  
9 *Incident Report Form which shall include:*

- 10 (1) *The name of aquatic venue;*
- 11 (2) *The physical address of the aquatic venue;*
- 12 (3) *The name of the owner of the aquatic venue;*
- 13 (4) *The mailing address of the owner of the aquatic venue;*
- 14 (5) *The phone number of the owner of the aquatic venue;*
- 15 (6) *The name of the aquatic venue management company, if applicable;*
- 16 (7) *The license classification of the aquatic venue;*
- 17 (8) *The type of aquatic venue;*
- 18 (9) *The type of use;*
- 19 (10) *The date and time of the incident;*
- 20 (11) *The type of incident;*
- 21 (12) *Who the victim was treated by on-site;*
- 22 (13) *Whether cardiopulmonary resuscitation was required;*
- 23 (14) *Who performed the resuscitation, if applicable;*
- 24 (15) *Whether an automated external defibrillator was used;*
- 25 (16) *Whether the victim was admitted to the hospital;*
- 26 (17) *The name of the hospital, if applicable;*

Draft Regulations for COMAR 10.17.01 – Aquatic Facilities and Venues

- 1 (18) *Whether the incident resulted in death;*
- 2 (19) *The date and time of death, if applicable;*
- 3 (20) *The emergency response units and associated report numbers;*
- 4 (21) *Whether a certified aquatic venue operator was present during the incident;*
- 5 (22) *Whether a lifeguard was present during the incident;*
- 6 (23) *The number of lifeguards present, if lifeguards were on duty;*
- 7 (24) *An attached aquatic venue:*
  - 8 (a) *Diagram showing the locations of the victim;*
  - 9 (b) *Diagram showing the location of each lifeguard, if applicable;*
  - 10 (c) *Supervision plan;*
  - 11 (d) *List of house rules;*
  - 12 (e) *Emergency plan;*
  - 13 (f) *Lifeguard certification; and*
  - 14 (g) *Certified aquatic venue operator card;*
- 15 (25) *The State or local agencies notified;*
- 16 (26) *The date and time the State or local agency was notified;*
- 17 (27) *The name of the person that was notified, if notification occurred by telephone;*
- 18 (28) *The signature of the owner or operator completing the form;*
- 19 (29) *The printed name of the owner or operator completing the form;*
- 20 (30) *The phone number of the owner or operator completing the form;*
- 21 (31) *The email address of the owner or operator completing the form; and*
- 22 (32) *The fax number of the owner or operator completing the form; and*
- 23 *E. All fecal, vomit or blood incidents that occur at an aquatic venue are recorded in the Fecal,*
- 24 *Vomit, Blood Incident Response log which shall include:*

## Draft Regulations for COMAR 10.17.01 – Aquatic Facilities and Venues

- 1 *(1) Date of the incident;*
- 2 *(2) The time of the incident;*
- 3 *(3) Levels for the following prior to treating the water at the aquatic venue:*
  - 4 *(a) Free chlorine residual in ppm;*
  - 5 *(b) pH; and*
  - 6 *(c) Temperature in degrees Fahrenheit;*
- 7 *(4) Levels for the following at the halfway point for treating the water at the aquatic venue:*
  - 8 *(a) Free chlorine residual in ppm;*
  - 9 *(b) pH; and*
  - 10 *(c) Temperature in degrees Fahrenheit;*
- 11 *(5) Levels for the following at the end of treating the water at the aquatic venue:*
  - 12 *(a) Free chlorine residual in ppm;*
  - 13 *(b) pH; and*
  - 14 *(c) Temperature in degrees Fahrenheit;*
- 15 *(6) Date bacteriological samples were taken; and*
- 16 *(7) The four locations where the bacteriological samples were taken from within the aquatic*
- 17 *venue.*

### **Summary of changes:**

#### **MAHC:**

#### **Relevant comments:**

- 2015-015
- 2015-047
- 2015-098
- 2017-157
- 2017-252



## Draft Regulations for COMAR 10.17.01 – Aquatic Facilities and Venues

### 1 **.52 [Disinfection of Swimsuits and Towels.**

2 An owner shall ensure that a swimsuit or towel furnished to an individual by the owner or  
3 operator of a public pool or spa is:

4 A. Washed in a washing machine with laundry detergent in hot water with a temperature of at  
5 least 175(F; and

6 B. Rinsed in an effective disinfectant or heat dried at 175(F or more for at least 30 minutes after  
7 being washed.]

### 8 ***Standardization and Audits of Local Health Departments.***

9 *A. The Department shall:*

10 *(1) Standardize one local standardization officer related to the enforcement of this chapter for*  
11 *each local health department;*

12 *(2) Audit local health department aquatic venue programs related to the enforcement of this*  
13 *chapter once every four years according to the current audit protocols; and*

14 *(3) Provide to the local health department an aquatic venue program review final report.*

15 *B. Local health departments shall submit to the Department responses to any deficiencies within*  
16 *the aquatic venue program as identified within the aquatic venue program review final report*  
17 *within 30 business days of receipt of the report.*

**Summary of changes:** .52

**MAHC:**

**Relevant comments:**

- 2015-099
- 2017-052
- 2017-254

**Summary of changes:** .60 – Emergency Eyewash (added in 2017)

**MAHC:**

**Relevant comments:**

-

## Draft Regulations for COMAR 10.17.01 – Aquatic Facilities and Venues

**Summary of changes:** .61 – Standards for Float Tanks (added in 2017)

**MAHC:**

**Relevant comments:**

- 2017-133

1 **.53 Variances.**

2 A. An owner who has been granted a variance by the Secretary before February 10, 1997 may  
3 continue to operate under that variance.

4 B. An owner may request a variance from a requirement of this chapter by submitting a written  
5 application that:

6 (1) Contains specific details of the alternative procedure proposed by the owner;

7 (2) Specifies the applicable regulation to which the variance pertains;

8 (3) Explains the reason for the request;

9 (4) Provides the name and address of the owner;

10 (5) Provides the name and location of the facility; and

11 (6) Demonstrates that the alternative procedure proposed:

12 (a) Meets or produces the intended effect of the regulation for which the variance is requested[.];  
13 and

14 (b) Maintains the protection of the health and safety of the individuals using the facility at or  
15 above the level required by the regulation for which the variance is requested.

16 C. Upon consideration of an application for a variance, the Secretary may grant the request for a  
17 variance if the:

18 (1) Applicant has submitted an application in accordance with the provisions of §B of this  
19 regulation;

20 (2) Applicant has complied with all other applicable provisions of this chapter;

21 (3) Application is justified due to physical limitation of the existing layout of the facility; and

22 (4) Secretary determines that the alternative procedure proposed by the applicant:

## Draft Regulations for COMAR 10.17.01 – Aquatic Facilities and Venues

1 (a) Meets or produces the intended effect of the regulation[.]; and

2 (b) Maintains the protection of the health and safety of the individuals using the facility at or  
3 above the level required by the regulation at issue.

4 D. The Secretary shall grant or deny an application for a variance in writing and shall mail the  
5 decision to the applicant within 60 *business* days of the date the application for a variance is  
6 received by the Department.

7 E. If the determination of the Secretary is to deny a variance request that has been made in  
8 compliance with the provisions of §B of this regulation, the applicant may file an appeal of the  
9 denial in accordance with State Government Article, Title 10, Subtitle 2, Annotated Code of  
10 Maryland, and shall contact the Secretary within 10 *calendar* days of receipt of the denial to  
11 preserve a right to a hearing.

12 F. A local health department that issues or denies a variance under the authority of the Secretary  
13 shall mail a copy of the variance application and response to the Department within 60 *business*  
14 days of the date the application for a variance is received by the local health department.

### Summary of changes:

#### MAHC:

#### Relevant comments:

- 2015-100
- 

### 15 **.54 Compliance Schedules.**

16 A. The owner of [a public pool or, spa] *an aquatic venue* that has a structure, equipment, or  
17 appurtenance that is not in compliance with this chapter as determined by the Secretary may  
18 submit to the Secretary for approval a compliance schedule for meeting the requirements of this  
19 chapter.

20 B. The request from an owner for approval of a compliance schedule shall include:

21 (1) The reason that the [noncompliance] *noncompliant* item cannot be immediately corrected;

22 (2) The plan for correction of the [noncompliance] *noncompliant* item; and

23 (3) The time schedule for the correction of the [noncompliance] *noncompliant* item.

24 C. The Secretary may approve the compliance schedule if the:

## Draft Regulations for COMAR 10.17.01 – Aquatic Facilities and Venues

- 1 (1) Owner has submitted a written request for approval of a compliance schedule in accordance  
2 with §B of this regulation;
- 3 (2) Time schedule for the correction of the [noncompliance] *noncompliant* item is accepted by  
4 the Secretary; and
- 5 (3) Operation of [the pool or, spa] *an aquatic venue* during the time allowed to bring the [pool or,  
6 spa]*aquatic venue* into compliance does not adversely affect the health and safety of the public.
- 7 D. The Secretary may not approve a compliance schedule for a newly constructed [pool or, spa]  
8 *aquatic venue* that has not received construction approval under Regulation .08 of this chapter.
- 9 E. The Secretary shall issue an operating permit or shall refrain from suspending an operating  
10 permit to an owner if:
- 11 (1) A compliance schedule has been approved by the Secretary for the correction of a  
12 [noncompliance] *noncompliant* item;
- 13 (2) The owner is following the approved compliance schedule; and
- 14 (3) [The pool or, spa] *An aquatic venue* is otherwise in compliance with this chapter.
- 15 *F. A local health department that issues or denies a compliance schedule under the authority of*  
16 *the Secretary shall mail a copy of the compliance schedule application and response to the*  
17 *Department within 60 business days of the date the application for a compliance schedule is*  
18 *received by the local health department.*

### Summary of changes:

#### MAHC:

#### Relevant comments:

- 

### 19 *.55 Bonding.*

20 *A. An owner shall ensure that once every 5 years a licensed electrician:*

21 *(1) Tests all metal and electrical equipment connected with the aquatic venue;*

22 *(2) Signs a bonding certification affidavit; and*

## Draft Regulations for COMAR 10.17.01 – Aquatic Facilities and Venues

1 (3) *Submits the bonding certification affidavit to the Department prior to the previous bonding*  
2 *certification affidavit expiring.*

3 *B. A bonding certification affidavit shall be valid for 5 years from the date signed by the licensed*  
4 *electrician.*

### Summary of changes:

#### MAHC:

#### Relevant comments:

- 2017-051
- 2017-066
- 2017-077
- 2017-132
- 2017-158
- 2017-253

### 5 **Administrative History**

6 Effective date: February 10, 1997 (24:3 Md. R. 187)

7 Chapter revised as an emergency provision effective July 1, 1999 (26:16 Md. R. 1238); amended  
8 permanently effective December 13, 1999 (26:25 Md. R. 1898)

9 Regulation .01A amended effective December 19, 2005 (32:25 Md. R. 1942)

10 Regulation .02 amended effective December 19, 2005 (32:25 Md. R. 1942)

11 Regulation .03 amended as an emergency provision effective January 3, 2014 (41:2 Md. R. 88);  
12 amended permanently effective May 12, 2014 (41:9 Md. R. 521)

13 Regulation .03A amended effective March 20, 2000 (27:5 Md. R. 584); December 19, 2005  
14 (32:25 Md. R. 1942)

15 Regulation .04 amended as an emergency provision effective December 19, 2008 (36:4 Md. R.  
16 345); amended permanently effective June 15, 2009 (36:12 Md. R. 837)

17 Regulation .04A, B amended effective December 19, 2005 (32:25 Md. R. 1942)

18 Regulation .05B amended effective March 20, 2000 (27:5 Md. R. 584); December 19, 2005  
19 (32:25 Md. R. 1942)

20 Regulation .05B amended as an emergency provision effective December 19, 2008 (36:4 Md. R.  
21 345); amended permanently effective June 15, 2009 (36:12 Md. R. 837)

## Draft Regulations for COMAR 10.17.01 – Aquatic Facilities and Venues

- 1 Regulation .05B amended as an emergency provision effective January 3, 2014 (41:2 Md. R. 88);  
2 amended permanently effective May 12, 2014 (41:9 Md. R. 521)
- 3 Regulation .06 amended as an emergency provision effective January 3, 2014 (41:2 Md. R. 88);  
4 amended permanently effective May 12, 2014 (41:9 Md. R. 521)
- 5 Regulation .08 amended as an emergency provision effective January 3, 2014 (41:2 Md. R. 88);  
6 amended permanently effective May 12, 2014 (41:9 Md. R. 521)
- 7 Regulation .09C amended effective March 20, 2000 (27:5 Md. R. 584)
- 8 Regulation .09E repealed effective December 19, 2005 (32:25 Md. R. 1942)
- 9 Regulation .12B amended effective December 19, 2005 (32:25 Md. R. 1942)
- 10 Regulation .13C amended effective December 19, 2005 (32:25 Md. R. 1942)
- 11 Regulation .14A amended effective December 19, 2005 (32:25 Md. R. 1942)
- 12 Regulation .15A amended effective December 19, 2005 (32:25 Md. R. 1942)
- 13 Regulation .16C, D amended effective December 19, 2005 (32:25 Md. R. 1942)
- 14 Regulation .17C, D amended effective December 19, 2005 (32:25 Md. R. 1942)
- 15 Regulation .18A amended effective December 19, 2005 (32:25 Md. R. 1942)
- 16 Regulation .21B amended effective December 19, 2005 (32:25 Md. R. 1942)
- 17 Regulation .22A amended effective December 19, 2005 (32:25 Md. R. 1942)
- 18 Regulation .25B amended effective December 19, 2005 (32:25 Md. R. 1942)
- 19 Regulation .25C amended effective March 20, 2000 (27:5 Md. R. 584)
- 20 Regulation .26 amended effective December 19, 2005 (32:25 Md. R. 1942)
- 21 Regulation .27 amended effective December 19, 2005 (32:25 Md. R. 1942)
- 22 Regulation .27F amended as an emergency provision effective January 3, 2014 (41:2 Md. R. 88);  
23 amended permanently effective May 12, 2014 (41:9 Md. R. 521)
- 24 Regulation .28 amended effective March 20, 2000 (27:5 Md. R. 584); December 19, 2005 (32:25  
25 Md. R. 1942)

## Draft Regulations for COMAR 10.17.01 – Aquatic Facilities and Venues

- 1 Regulation .28 amended as an emergency provision effective December 19, 2008 (36:4 Md. R.  
2 345); amended permanently effective June 15, 2009 (36:12 Md. R. 837)
- 3 Regulation .28F, G amended as an emergency provision effective January 3, 2014 (41:2 Md. R.  
4 88); amended permanently effective May 12, 2014 (41:9 Md. R. 521)
- 5 Regulation .35A amended effective December 19, 2005 (32:25 Md. R. 1942)
- 6 Regulation .40 amended effective March 20, 2000 (27:5 Md. R. 584); December 19, 2005 (32:25  
7 Md. R. 1942)
- 8 Regulation .41B amended effective December 19, 2005 (32:25 Md. R. 1942)
- 9 Regulation .43 amended effective March 20, 2000 (27:5 Md. R. 584)
- 10 Regulation .46 amended effective March 20, 2000 (27:5 Md. R. 584)
- 11 Regulation .53A amended as an emergency provision effective January 3, 2014 (41:2 Md. R.  
12 88); amended permanently effective May 12, 2014 (41:9 Md. R. 521)